



SERVICE INFORMATION	11-1
TROUBLESHOOTING	11-2
PRIMARY SHAFT DISASSEMBLY	11-3
STARTER CLUTCH DISASSEMBLY	11-4
STARTER IDLE GEAR REMOVAL	11-4
PRIMARY CHAIN TENSIONER REMOVAL	11-5
PRIMARY NOZZLE REMOVAL	11-6
TRANSMISSION DISASSEMBLY	11-7
SHIFT FORK AND SHIFT DRUM REMOVAL	11-9
SHIFT DRUM AND SHIFT FORK INSTALLATION	11-11
TRANSMISSION ASSEMBLY	11-12
PRIMARY SHAFT ASSEMBLY	11-14

SERVICE INFORMATION

GENERAL INSTRUCTIONS

- The gearshift linkage can be serviced with the engine in the frame.
- For internal transmission repairs, the crankcase must be separated (Refer to Section 10).

SPECIAL TOOLS

Special Tools		Common Tools	
Torx Driver Bit	07703-0010200	Driver Handle (B)	07746-0020100
Driver attachment	07947-6710100	Driver Handle (C)	07746-0030100
		Driver inner (25 mm)	07746-0030200
		Driver Handle (A)	07749-0010000
		Driver Pilot (22 mm)	07746-0041000

TORQUE VALUES

Neutral switch rotor	0.6-1.0 kg-m (4-7 ft-lb)
Primary chain tensioner	1.0-1.4 kg-m (7-10 ft-lb)
Primary chain nozzle	0.8-1.2 kg-m (6-9 ft-lb)
Starter clutch	1.2-1.6 kg-m (9-12 ft-lb)

SPECIFICATIONS

ITEM		STANDARD	SERVICE LIMIT
Transmission	Backlash	1st, 2nd, 3rd	0.044-0.133 mm (0.0017-0.0052 in) 0.20 mm (0.008 in)
		4th, 5th	0.046-0.140 mm (0.0018-0.0055 in) 0.20 mm (0.008 in)
	Gear I. D.	M4	25.020-25.041 mm (0.9850-0.9859 in) 25.06 mm (0.987 in)
		M5	23.000-23.033 mm (0.9055-0.9068 in) 23.06 mm (0.908 in)
		C1	24.000-24.033 mm (0.9449-0.9462 in) 24.06 mm (0.947 in)
		C2, C3	25.020-25.041 mm (0.9850-0.9859 in) 25.07 mm (0.987 in)
	Gear bushing	M5 O. D.	22.984-22.993 mm (0.9849-0.9052 in) 22.96 mm (0.904 in)
		M5 I. D.	20.010-20.030 mm (0.8665-0.7886 in) 20.07 mm (0.790 in)
		C1 O. D.	23.984-23.993 mm (0.9443-0.9446 in) 23.95 mm (0.943 in)
		C1 I. D.	20.010-20.030 mm (0.8665-0.7886 in) 20.07 mm (0.790 in)



ITEM			STANDARD	SERVICE LIMIT
Transmission	Mainshaft O.D.	at M4	24.959–24.980 mm (0.9826–0.9835 in)	24.93 mm (0.981 in)
		at M5	19.987–20.000 mm (0.7869–0.7874 in)	19.93 mm (0.785 in)
	Countershaft O. D.	at C1	19.987–20.000 mm (0.7869–0.7874 in)	19.93 mm (0.785 in)
		at C2, C3	24.959–24.980 mm (0.9826–0.9835 in)	24.93 mm (0.981 in)
	Gear to bushing or shaft clearance	M4 to shaft	————	0.10 mm (0.004 in)
		M5 to bushing	————	0.10 mm (0.004 in)
		M5 bushing to shaft	————	0.10 mm (0.004 in)
		C1 to bushing	————	0.10 mm (0.004 in)
		C1 bushing to shaft	————	0.10 mm (0.004 in)
		C2 to shaft	————	0.10 mm (0.004 in)
		C3 to shaft	————	0.10 mm (0.004 in)
End clearance	M5	0.3–0.5 mm (0.012–0.020 in)	————	
	C1	0.1–0.3 mm (0.004–0.012 in)	————	
Shift fork	Claw thickness		5.93–6.00 mm (0.233–0.236 in)	5.6 mm (0.22 in)
	I. D.	Center	38.000–38.025 mm (1.4961–1.4970 in)	38.075 mm (1.499 in)
		Left and right	13.000–13.018 mm (0.5118–0.5125 in)	13.04 mm (0.513 in)
Fork shaft	O. D.		12.966–12.984 mm (0.5104–0.5112 in)	12.90 mm (0.508 in)
Shift drum	O. D.		37.950–37.975 mm (1.4941–1.4951 in)	37.90 mm (1.492 in)
Electric starter	Drive gear O. D.		41.950–42.200 mm (1.6516–1.6614 in)	41.93 mm (1.650 in)
	Idle gear I. D.		10.000–10.015 mm (0.3937–0.3943 in)	10.04 mm (0.395 in)
	Idle gear shaft O. D.		9.972–9.987 mm (0.3926–0.3932 in)	9.95 mm (0.392 in)
	Idle gear-to-shaft clearance		————	0.1 mm (0.004 in)

TROUBLESHOOTING

Hard to shift

1. Improper clutch adjustment; too much free play
2. Shift fork bent
3. Shift shaft bent
4. Shift claw bent
5. Shift drum cam grooves damaged

Transmission jumps out of gear

1. Gear dogs worn
2. Shift shaft bent
3. Shift drum stopper broken
4. Shift forks bent



PRIMARY SHAFT DISASSEMBLY

Remove the primary shaft and separate the crankcase (see Section 10).

PRIMARY SHAFT INSPECTION

Check for scoring, wear or damage.

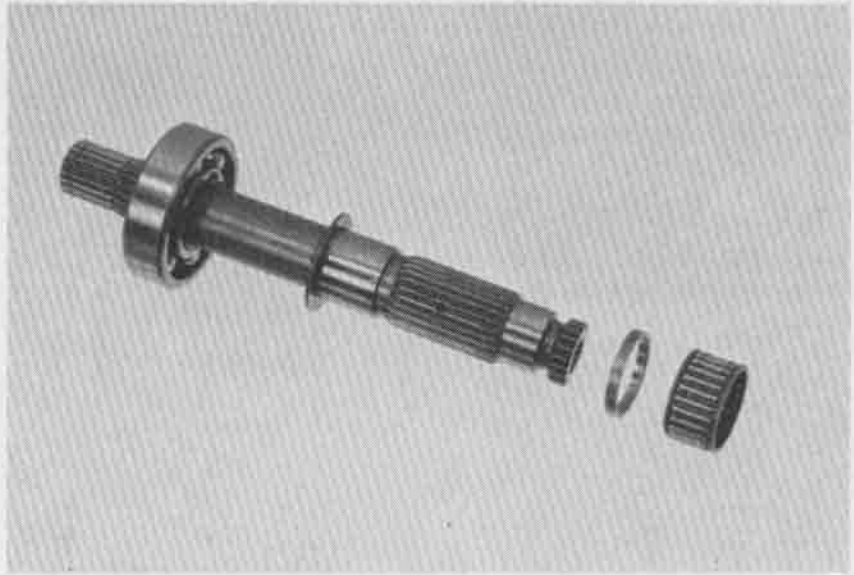

DAMPER DISASSEMBLY

Remove the circlip.
Remove the collar and cotters.

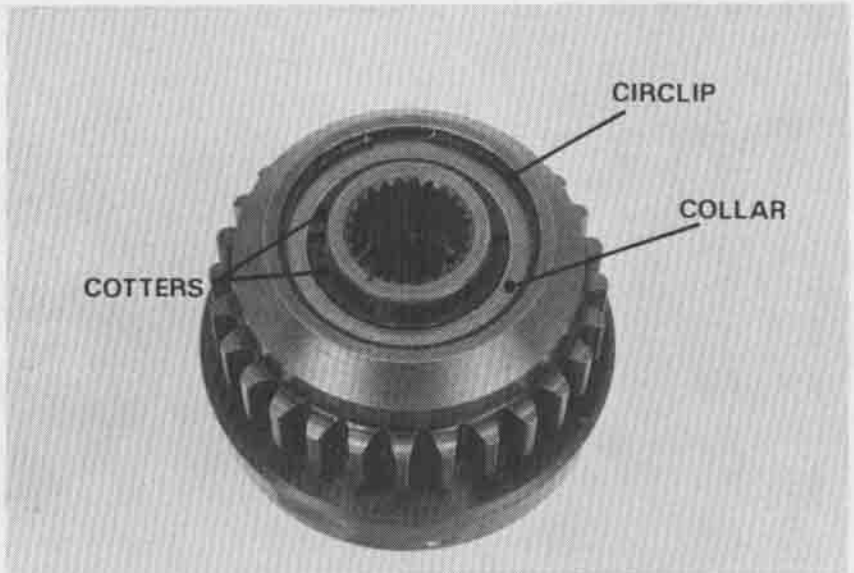

Remove the primary driven sprocket and damper rubbers.

DAMPER RUBBER INSPECTION

Check for damage or deterioration.

NOTE

Replace dampers as a set.

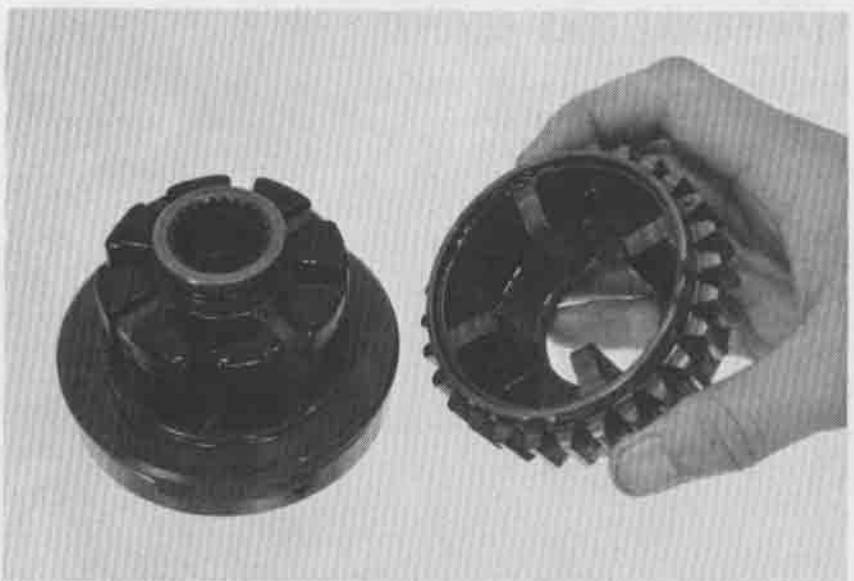



STARTER CLUTCH / DISASSEMBLY

Remove the "torx" bolts.
 Remove the starter clutch outer.
 Remove the rollers, plungers and springs.

STARTER CLUTCH INSPECTION

Inspect the rollers for smooth operation.
 Check the rollers for excessive wear.

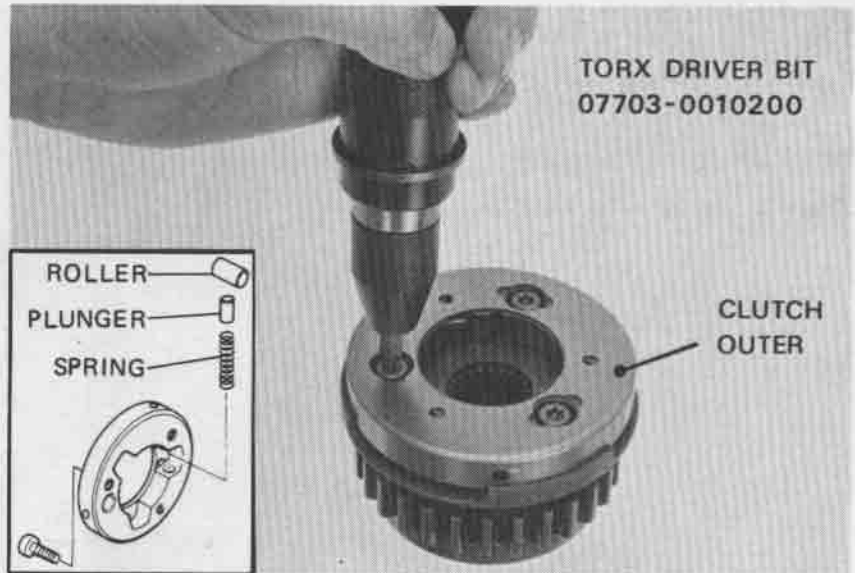
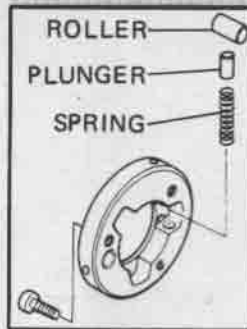

Inspect the drive gear for damage or excessive wear.

Measure the O. D.

SERVICE LIMIT: 41.93 mm (1.650 in)



STARTER IDLE GEAR REMOVAL

Straighten the set bolt lock washer tabs.
 Loosen the starter idle gear set bolt.
 Remove the idle gear shaft and gear.

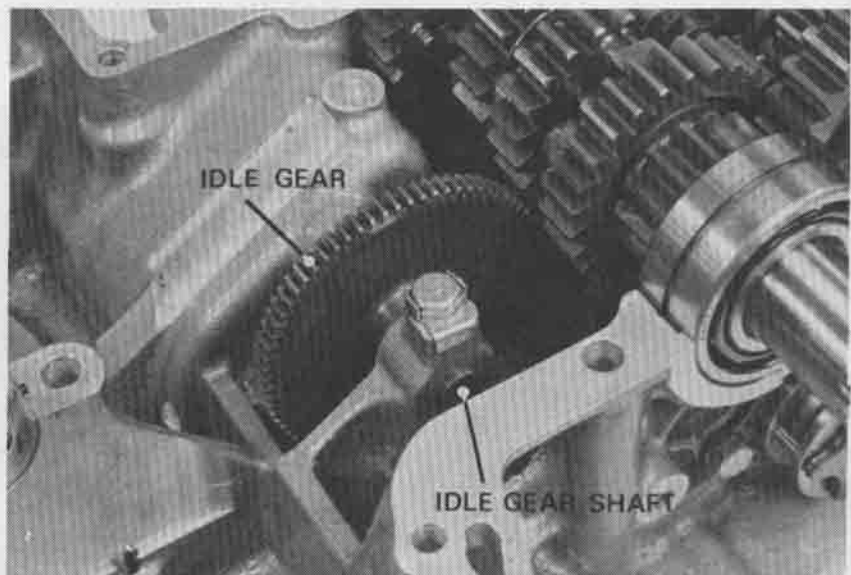



**STARTER IDLE GEAR AND
SHAFT INSPECTION**

Inspect the idle gear and shaft for damage or excessive wear.

Measure the gear I. D.

SERVICE LIMIT: 10.04 mm (0.395 in)

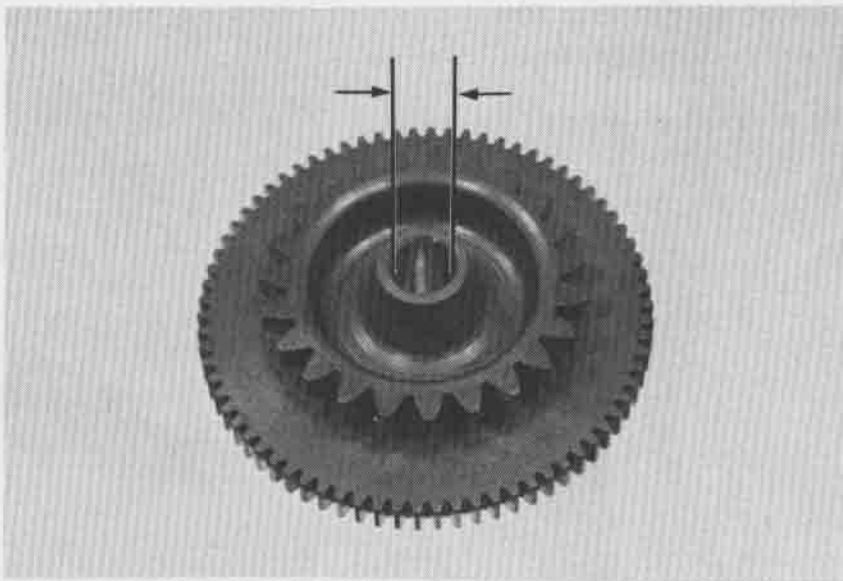

Measure the shaft O. D.

SERVICE LIMIT: 9.95 mm (0.392 in)

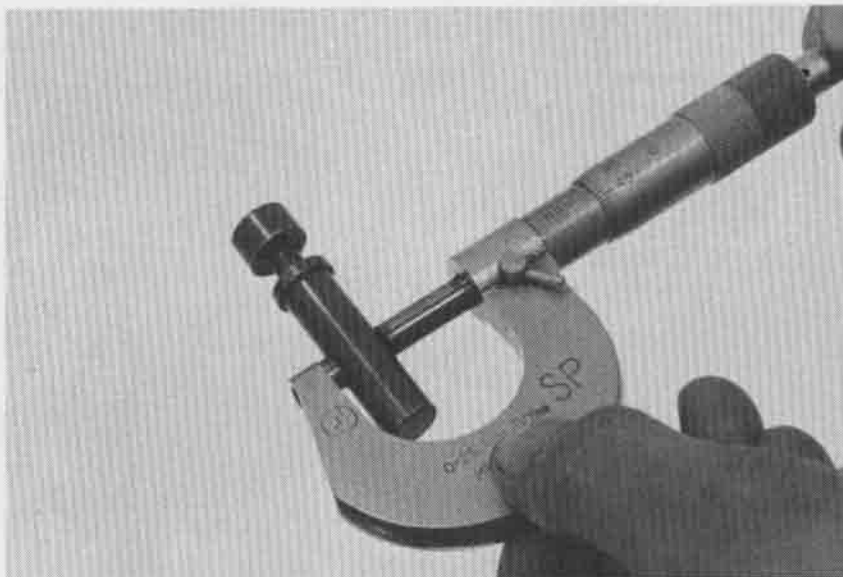

**PRIMARY CHAIN
TENSIONER REMOVAL**

Remove the tensioner bolt and tensioner.

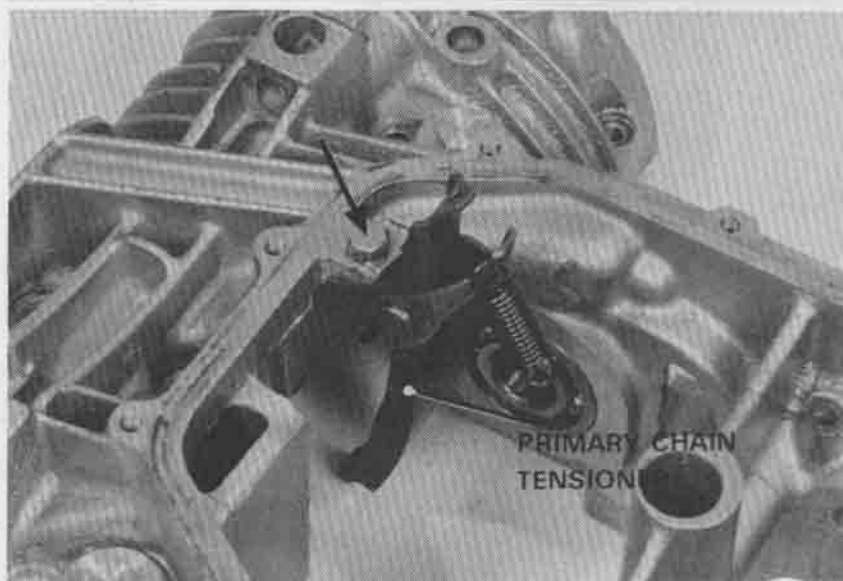



TENSIONER INSPECTION

Check the slipper for damage or excessive wear.

Replace the tensioner if the Teflon coating on the slipper is worn out.

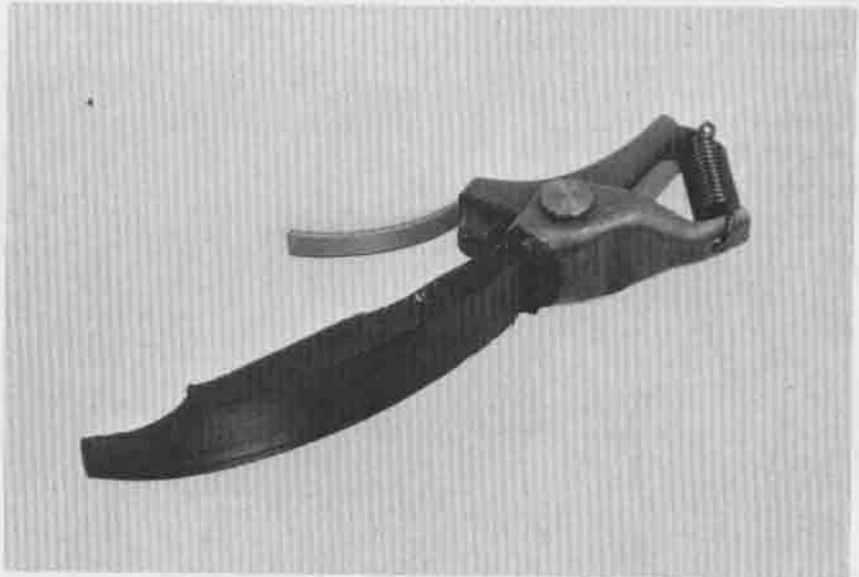

PRIMARY NOZZLE REMOVAL

Remove the primary nozzle.

Check that the nozzle is not clogged.

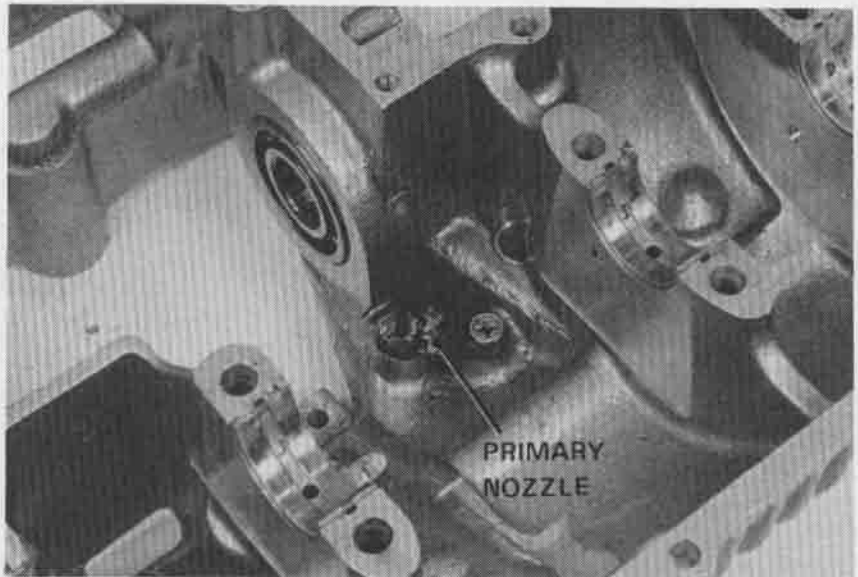



For servicing of the gearshift linkage, see Section 9.

TRANSMISSION DISASSEMBLY

Separate the crankcase (Section 10).
Inspect each gear for backlash.

SERVICE LIMIT: 0.20 mm (0.008 in)

Remove the mainshaft and countershaft.
Remove the dowel pins and bearing set rings from the crankcase.

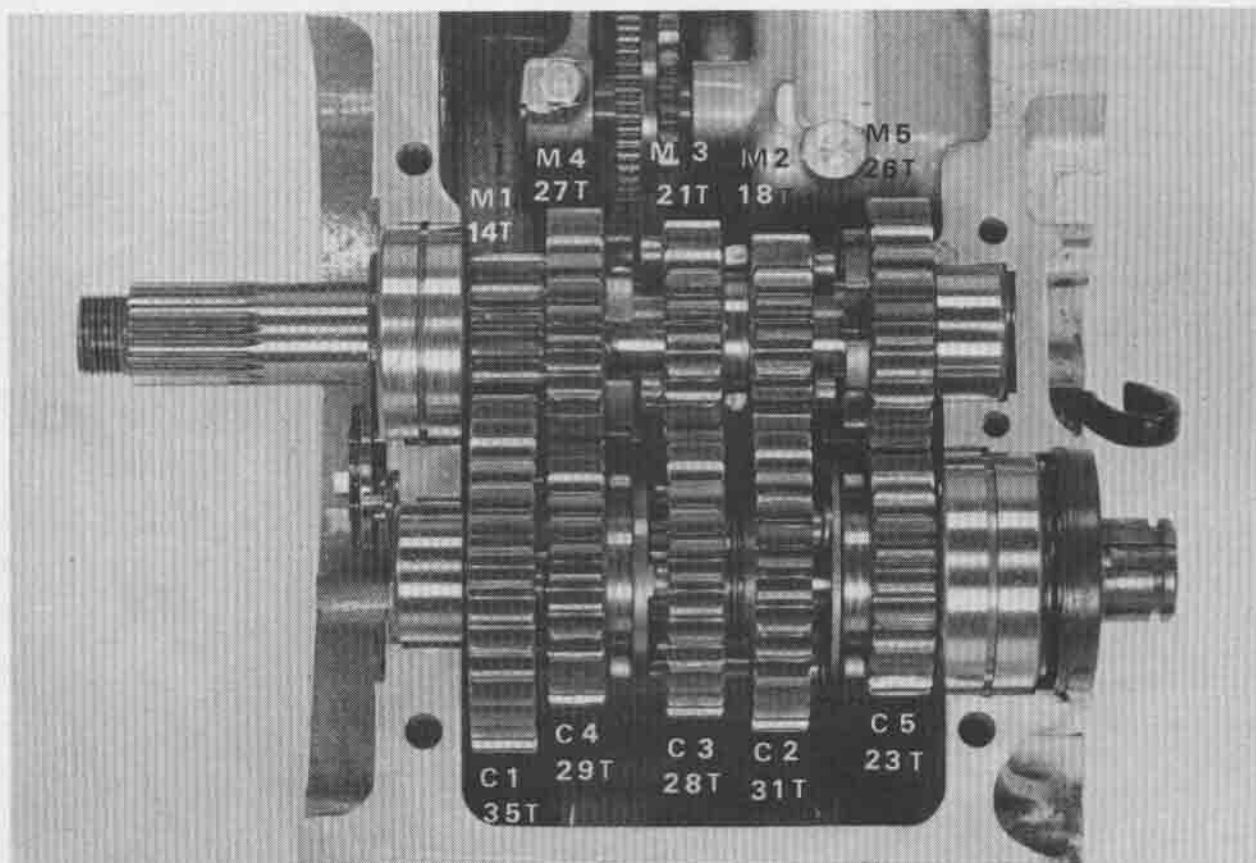
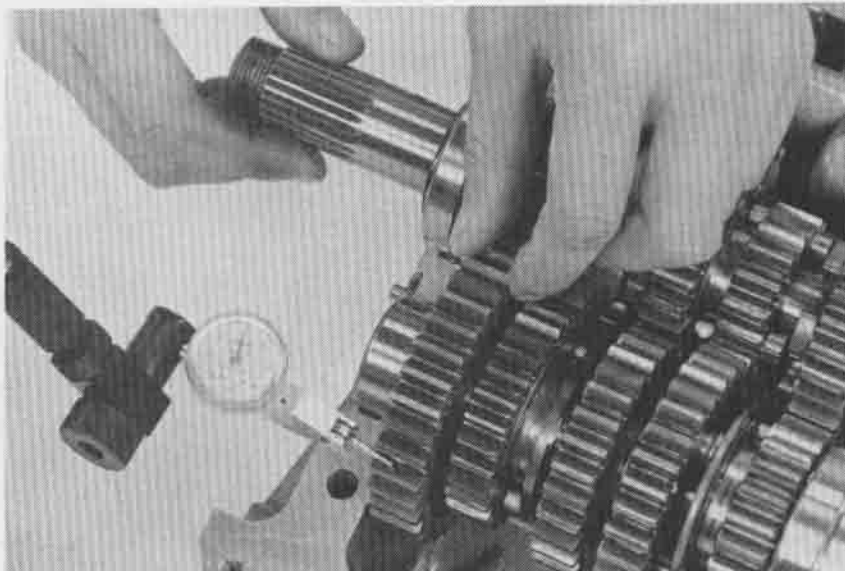



TRANSMISSION INSPECTION

Check gear dogs, dog holes and teeth for excessive or abnormal wear, or evidence of insufficient lubrication.

Measure the I. D. of each gear.

SERVICE LIMITS:

M4 gear: 25.06 mm (0.987 in)

M5 gear: 23.06 mm (0.908 in)

C1 gear: 24.06 mm (0.947 in)

C2 gear: 25.07 mm (0.987 in)

C3 gear: 25.07 mm (0.987 in)

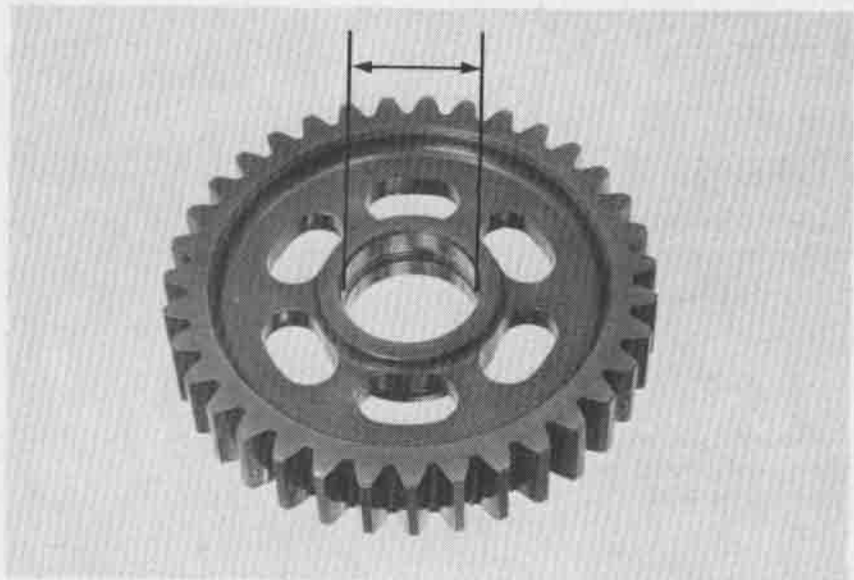

Measure the I. D. and O. D. of the gear bushings.

SERVICE LIMITS:

M5 O.D.: 22.96 mm (0.904 in)

M5 I.D.: 20.07 mm (0.790 in)

C1 O.D.: 23.95 mm (0.943 in)

C1 I.D.: 20.07 mm (0.790 in)

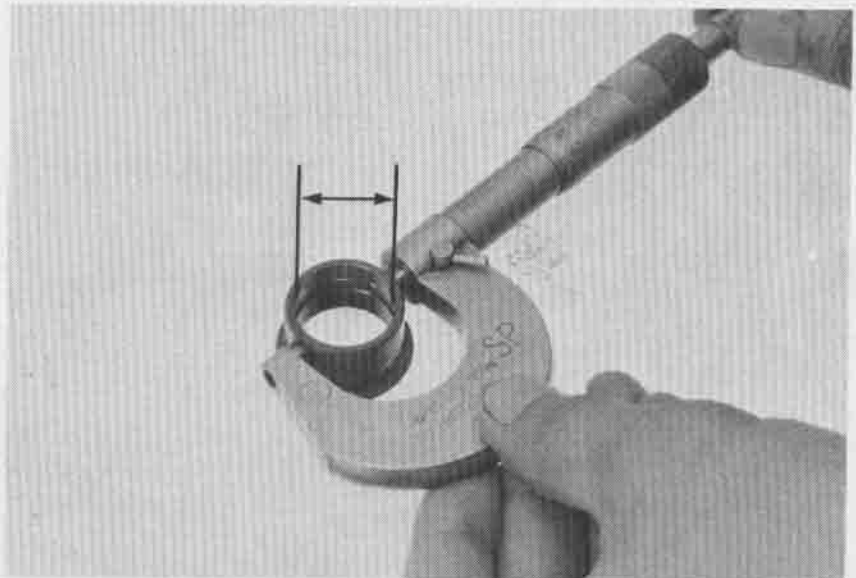

Measure the O. D. of the mainshaft and countershaft.

SERVICE LIMITS:

A: 24.93 mm (0.981 in)

B: 19.93 mm (0.785 in)

C: 19.93 mm (0.785 in)

Calculate the clearance between the gear and gear shaft or bushing.

SERVICE LIMIT: 0.10 mm (0.004 in)

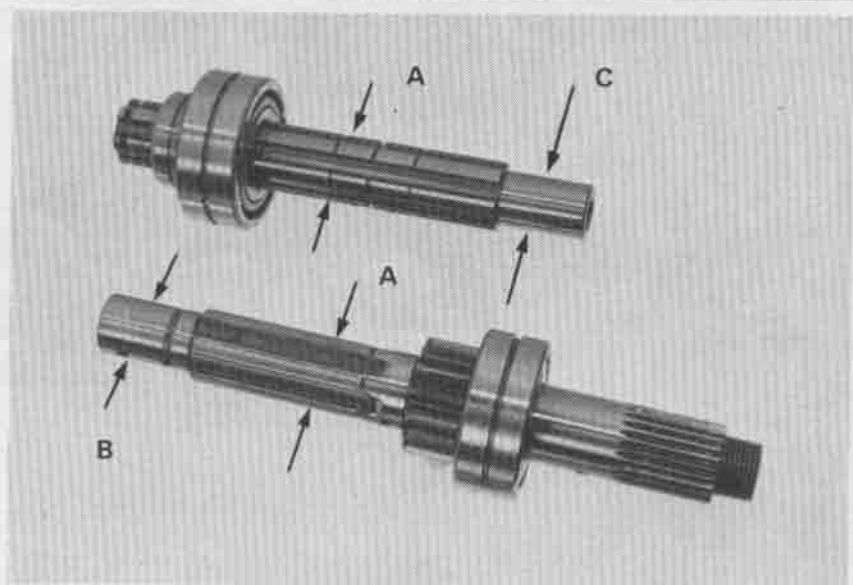



SHIFT FORK AND SHIFT DRUM REMOVAL

Remove the bearing stopper plate.
Remove the cam plate and shift drum center.

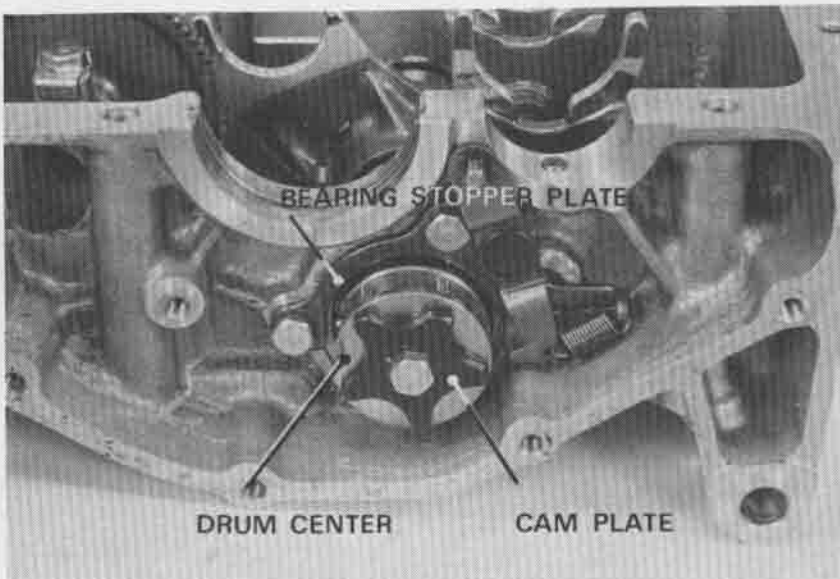

Remove the neutral switch.

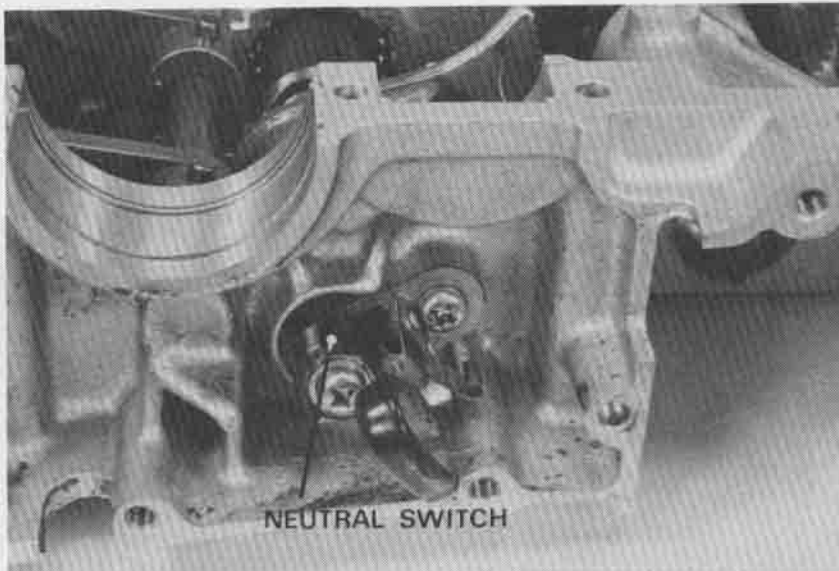

Remove the shift fork shaft and forks.
Remove the shift drum and bearing.

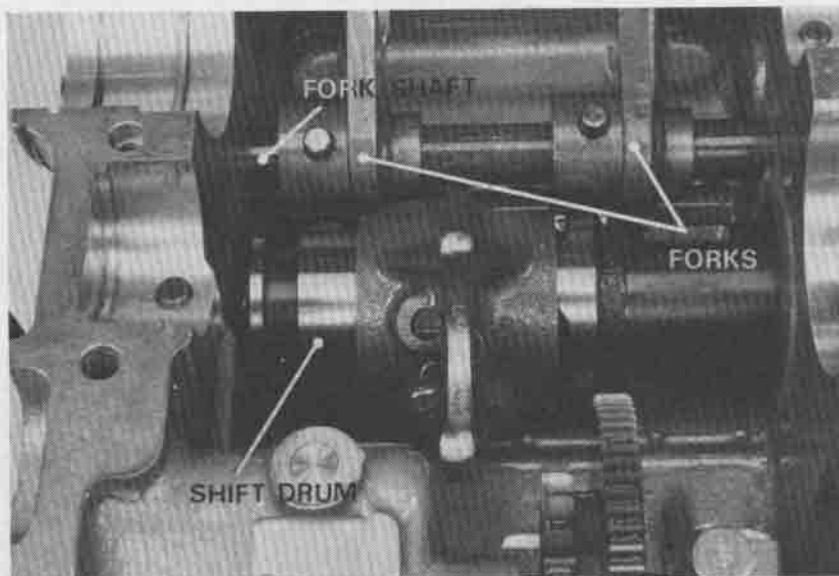



Remove the shift fork set pin clip.
 Remove the shift fork set pin and fork.

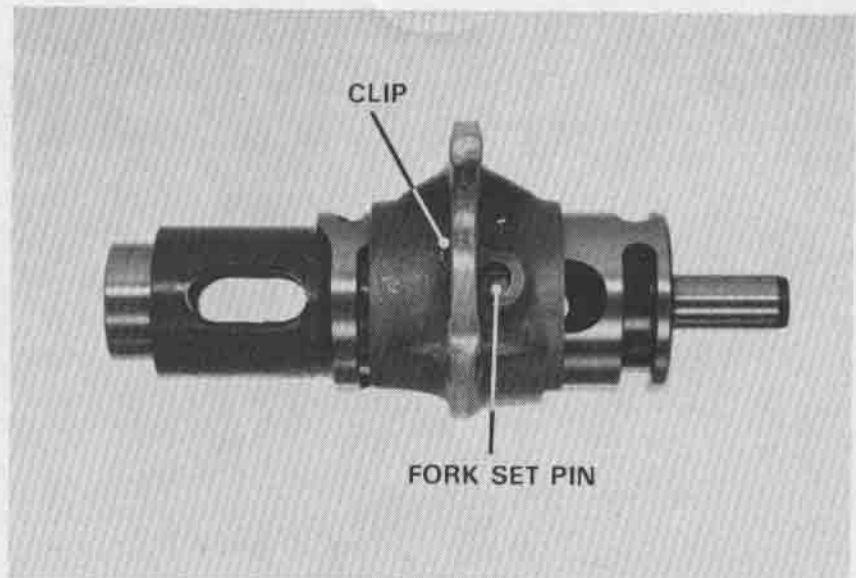

GEARSHIFT DRUM AND SHIFT FORK INSPECTION

Inspect the shift drum end for scoring, scratches, or evidence of insufficient lubrication.

Check the shift drum groove for damage.
 Measure the shift drum O. D.

SERVICE LIMIT: 37.90 mm (1.492 in)

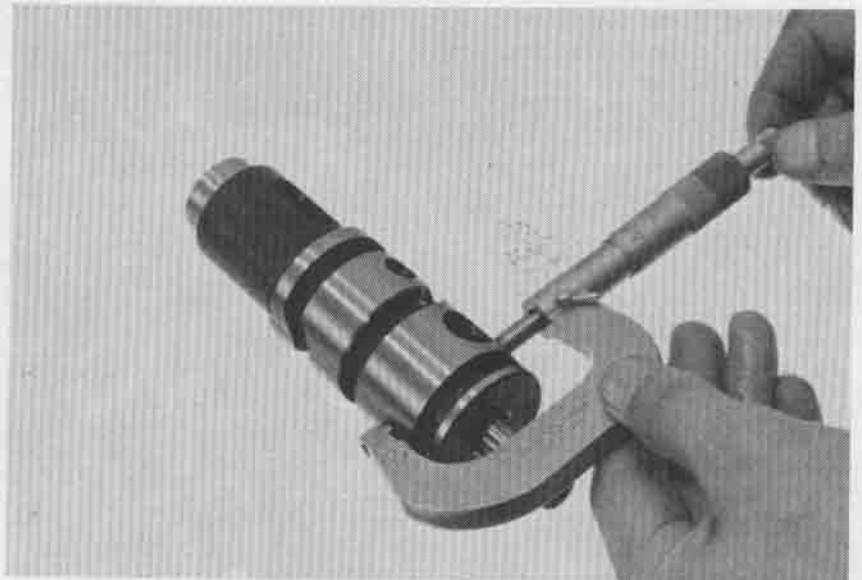

Measure the shift fork shaft O. D.

SERVICE LIMIT: 12.90 mm (0.508 in)

Check for scratches, scoring, or evidence of insufficient lubrication.

Inspect the shift drum hole and shift fork shaft hole for scoring or scratches.

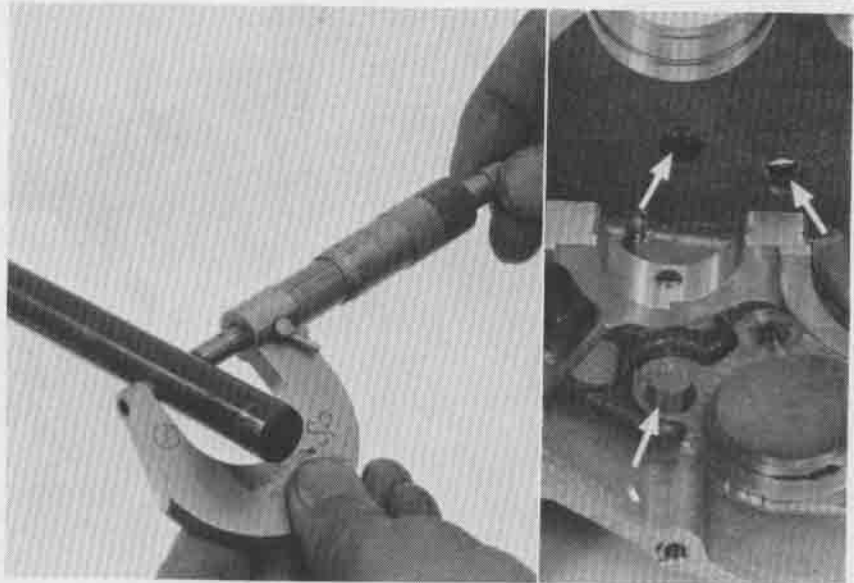



Measure the shift fork I.D. and claw thickness.

SERVICE LIMITS:

I.D. (L AND R): 13.04 mm (0.513 in)

I.D. (CENTER): 38.075 mm (1.499 in)

CLAW THICKNESS: 5.6 mm (0.22 in)

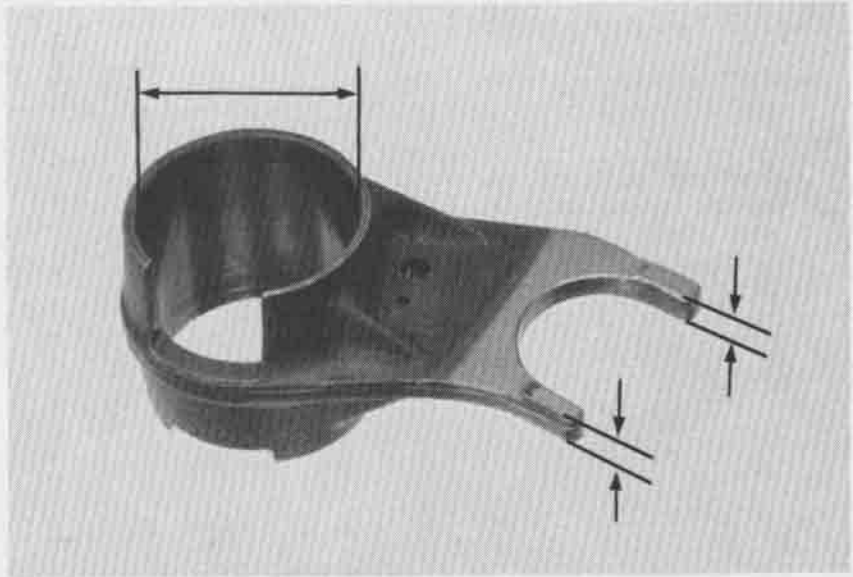

SHIFT DRUM AND SHIFT FORK INSTALLATION

Install the shift drum and shift forks by reversing the removal procedure.

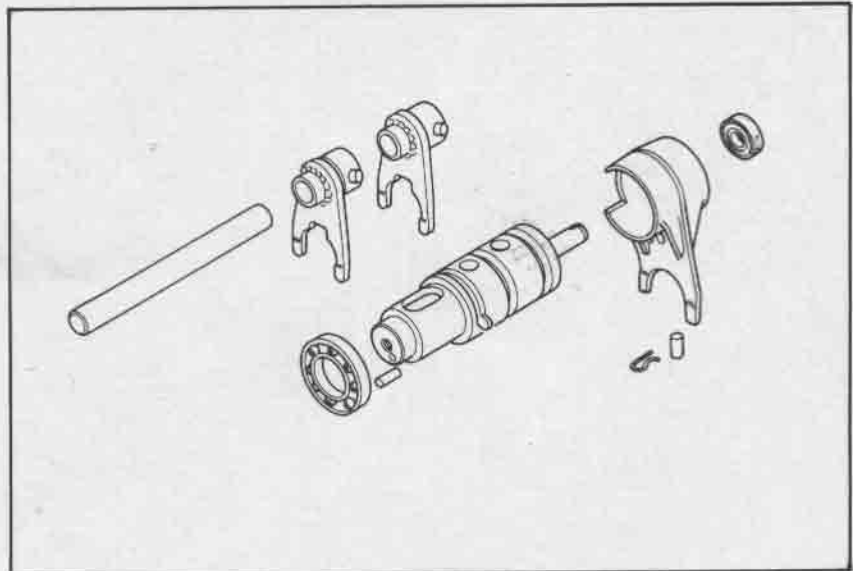

Align the tab on the neutral switch with the slot in the shift drum end.

TORQUE: 0.6–1.0 kg-m (4–7 ft-lb)

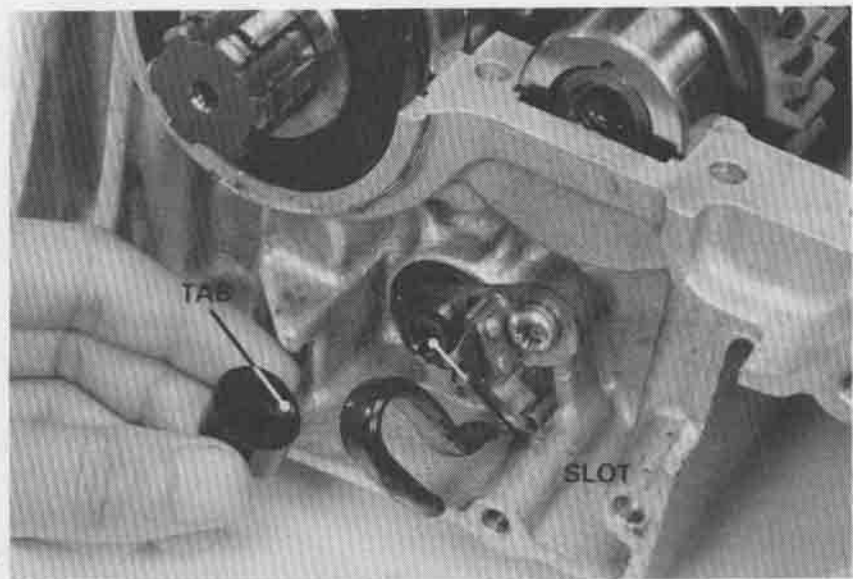



TRANSMISSION ASSEMBLY

Assemble the mainshaft and countershaft.

NOTE

- Check the gears for freedom of movement or rotation on the shaft.
- Check that the snap rings are seated in the grooves.

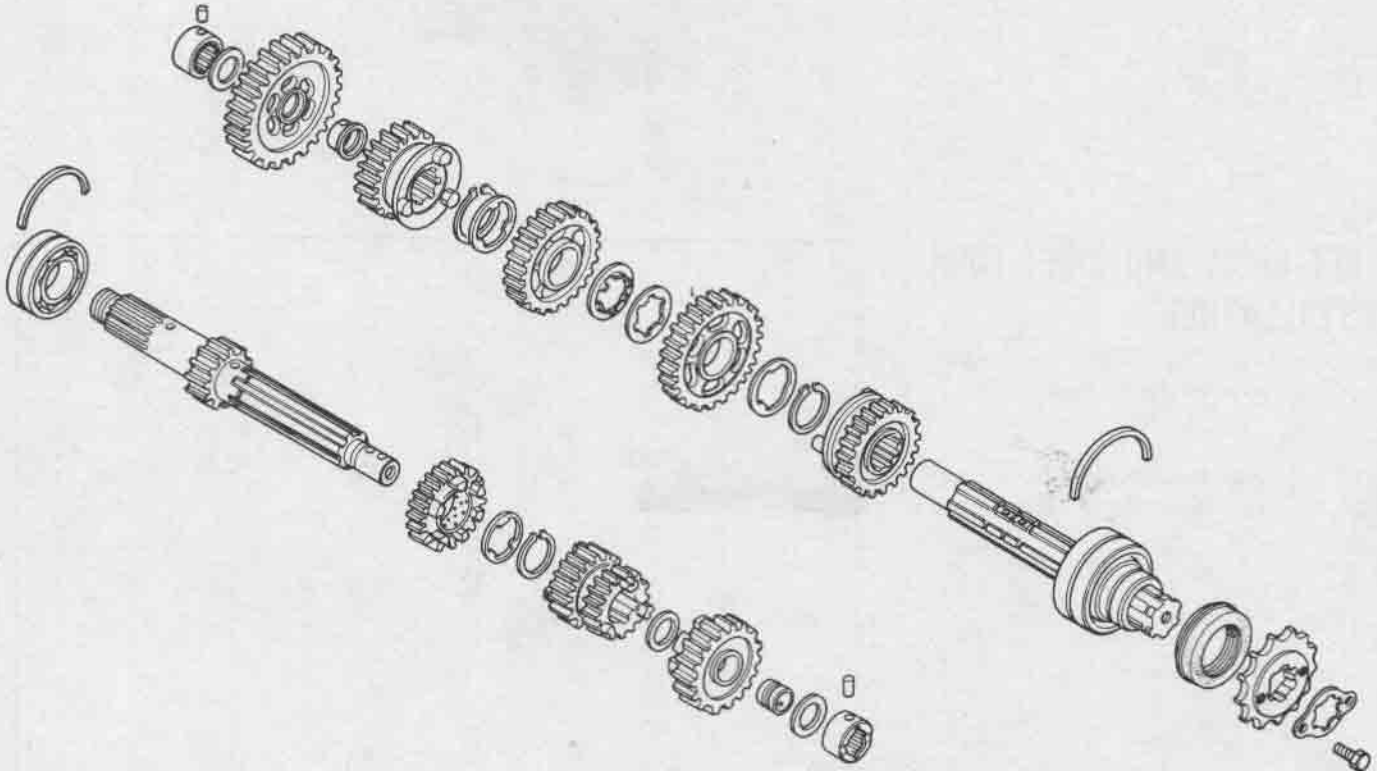

NOTE

Install the mainshaft bearing with special tools.



DRIVER
HANDLE (C)
DRIVER INNER
(25mm)



Install the dowel pins and bearing set rings.

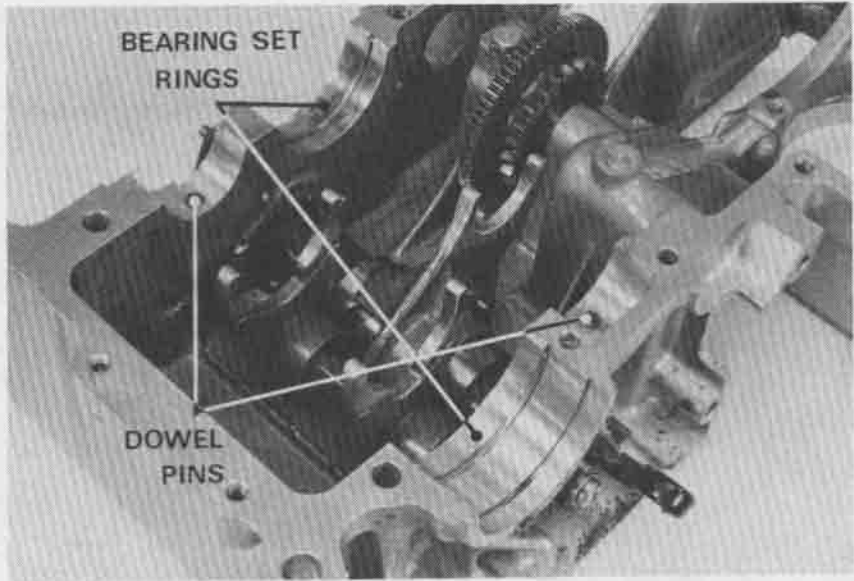

Align the hole in the needle bearings with the dowel pins by aligning the marks flush with the crankcase surface.

Align the ball bearing groove with the bearing set ring.

NOTE

To prevent oil leakage, push the counter-shaft oil seal in until the oil seal lip is seated completely on the bearing before assembling the lower crankcase.

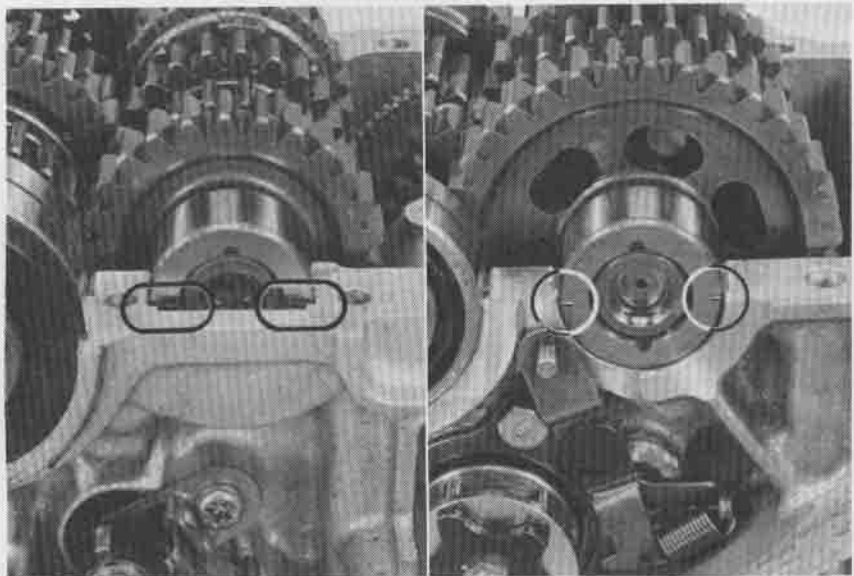

Assemble the crankcase (Refer to Section 10).



PRIMARY SHAFT ASSEMBLY

Install the primary chain nozzle.

TORQUE: 0.8–1.2 kg-m (6–9 ft-lb)

Install the tensioner and tighten the bolt.

TORQUE: 1.0–1.4 kg-m (7–10 ft-lb)

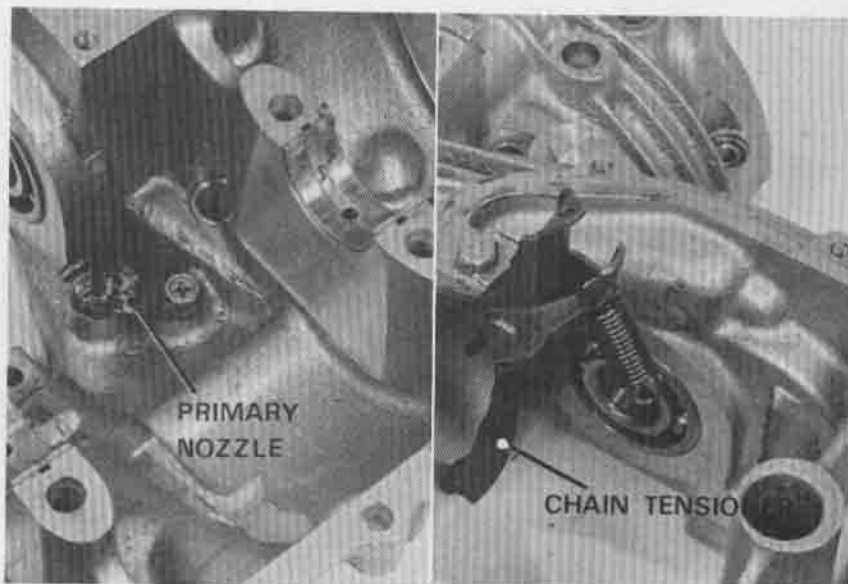

DAMPER ASSEMBLY

Install the damper rubbers.
 Install the primary sprocket.

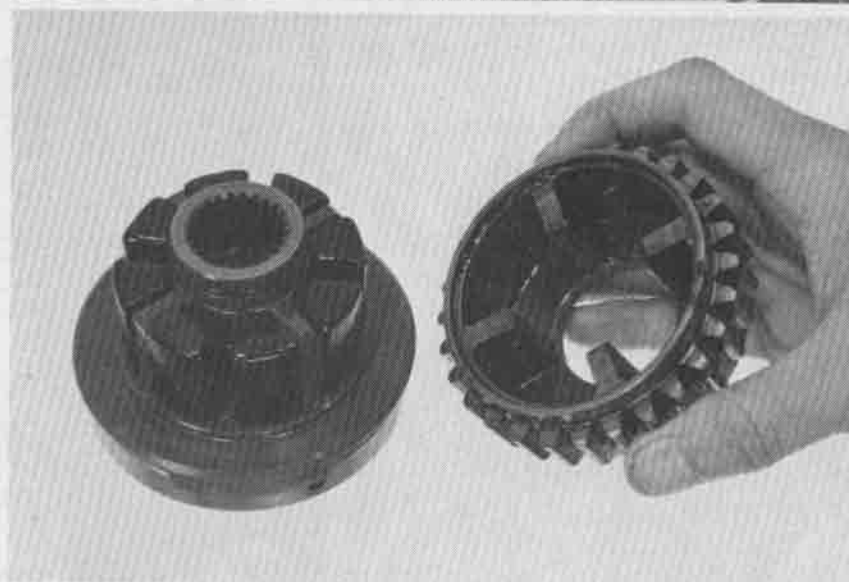

Install the cotters and collar.
 Install the circlip.

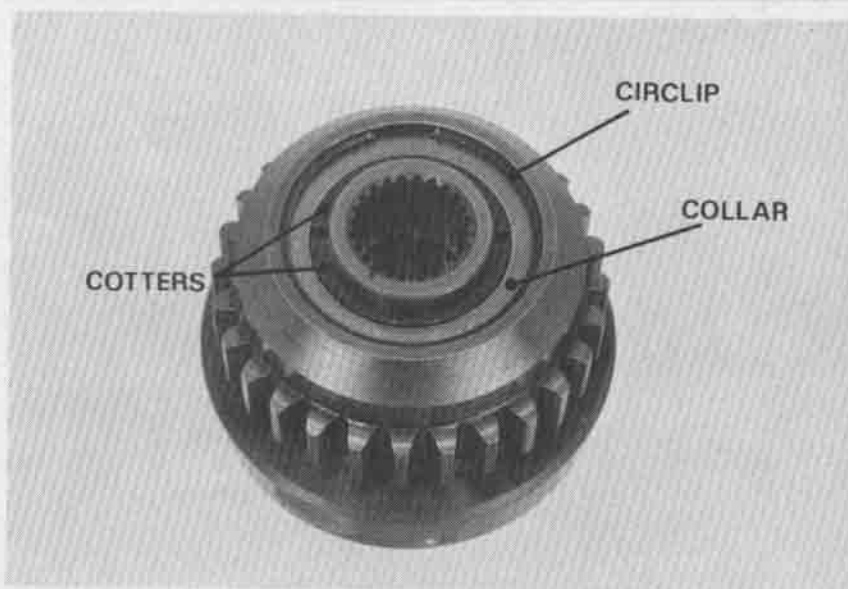



STARTER IDLE GEAR INSTALLATION

Install the starter idle gear and shaft.
Tighten the bolt and bend the lock washer tabs against the bolt.

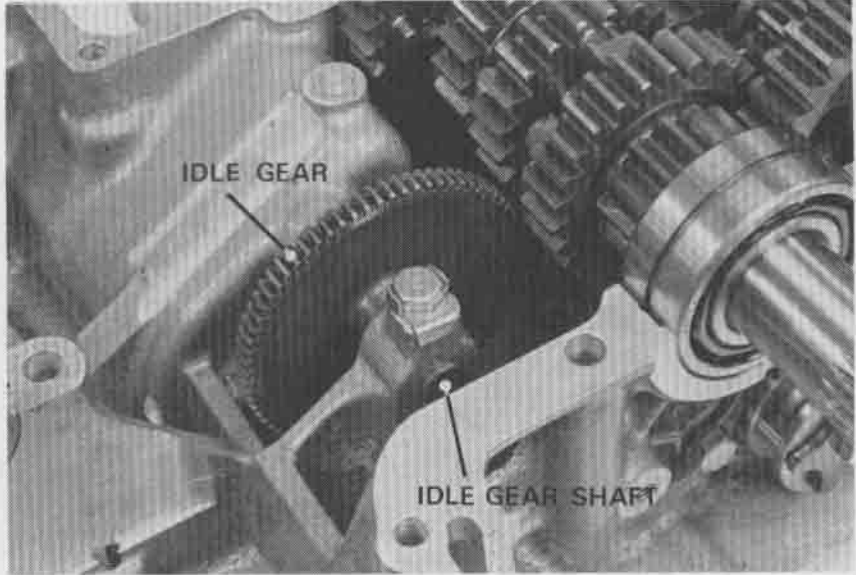

STARTER CLUTCH ASSEMBLY

Install the starter clutch outer.

TORQUE: 1.2-1.6 kg-m (9-12 ft-lb)

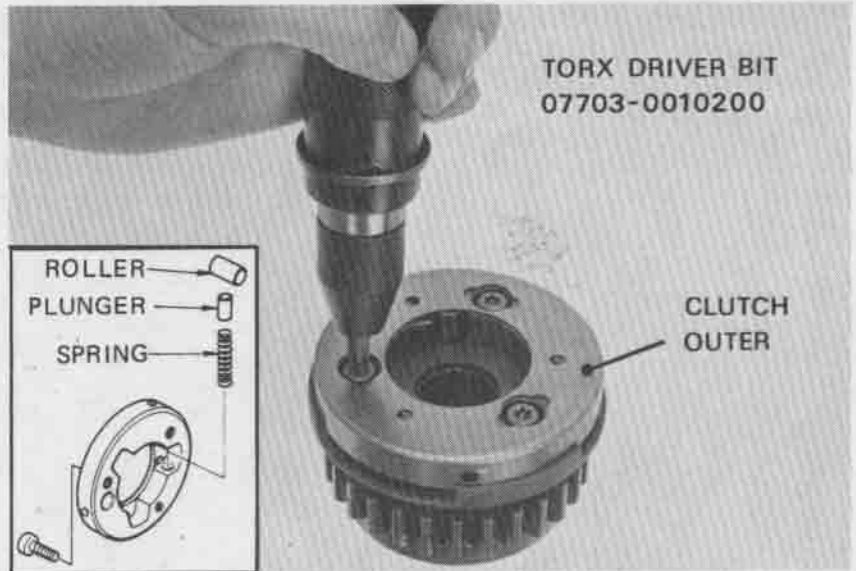

Install the starter clutch springs, plungers and rollers.

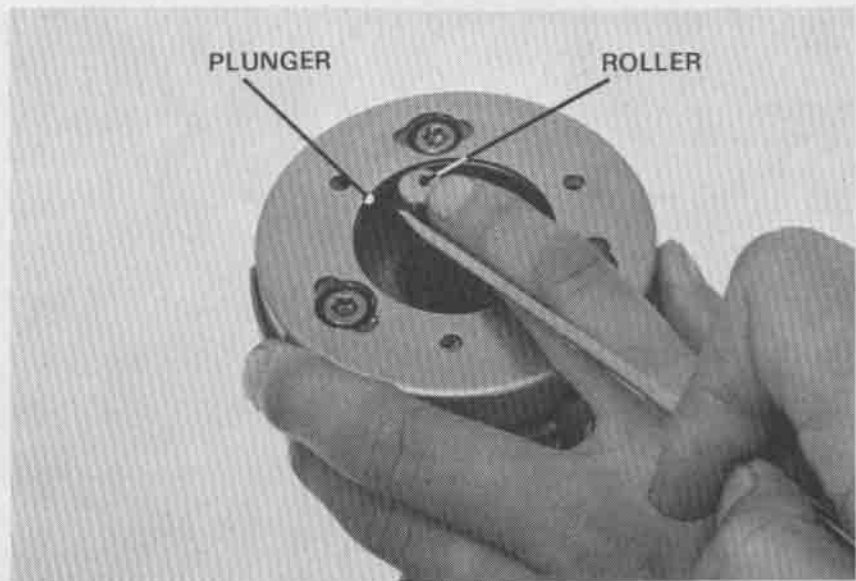



Rotate the starter drive gear counterclockwise while installing it.

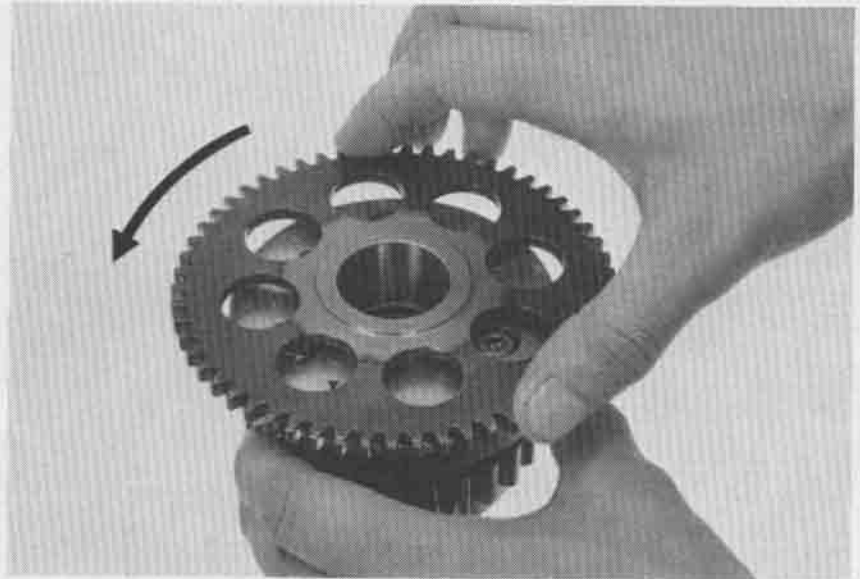

PRIMARY SHAFT ASSEMBLY

Install the bearing onto the primary shaft.

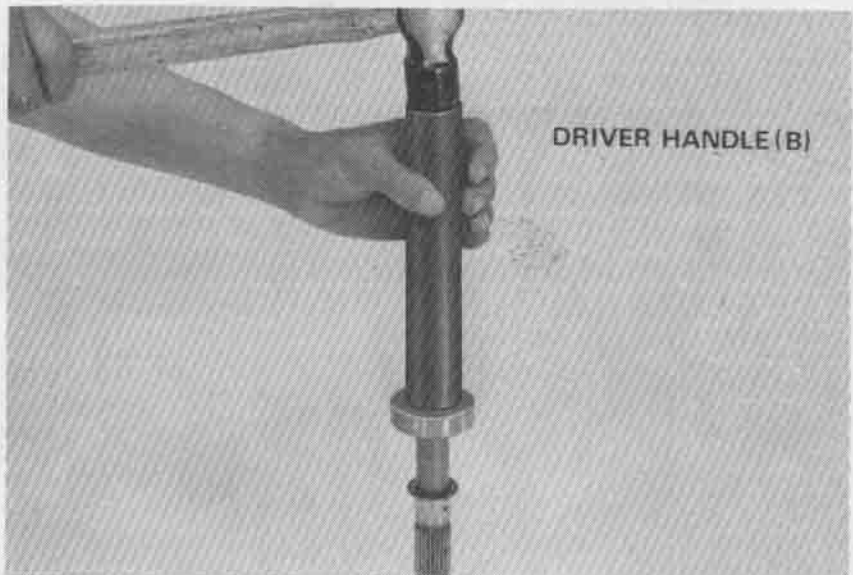

Install the bearing into the primary shaft bore.

Assemble the crankcase and install the primary shaft (Section 10).

