



SERVICE INFORMATION	10-1
CRANKCASE DISASSEMBLY	10-2
CRANKCASE ASSEMBLY	10-5

SERVICE INFORMATION

GENERAL INSTRUCTIONS

- To repair the crankshaft, connecting rod, primary shaft and transmission including the shift fork and drum, it is necessary to separate the crankcase halves.
- The following parts must be removed before disassembling the crankcase.

To service	Remove
Crankshaft and connecting rod	Cylinder head, cylinder, piston, A. C. generator rotor, clutch, pulser generator, gearshift linkage and oil pump
Transmission/primary shaft	Clutch, gearshift linkage, oil pump and pulser generator

SPECIAL TOOLS

- Special tools
- Sliding hammer shaft 07936-3740100
 - Sliding hammer weight 07945-3000500

TORQUE VALUES

- Crankcase 8 mm bolt 2.2-2.6 kg-m (16-19 ft-lb)
- Crankcase 6 mm bolt 1.0-1.4 kg-m (7-10 ft-lb)



CRANKCASE DISASSEMBLY

Remove the oil filter, oil pan and oil strainer (Section 2).

Remove the cylinder head, cylinders and pistons (Section 6 and 7).

Remove the clutch and gearshift linkage (Section 8 and 9).

Remove the A. C. generator, pulser generator, spark advancer and starting motor (Section 16, 17 and 18).

Remove the oil pump.

NOTE

The crankcase can be separated without removing the A. C. generator, starting motor, oil filter, oil pump and oil strainer. However, we recommend removal of these parts, because the transmission gears may be dropped when separating the crankcase.

Remove the upper crankcase bolts.
 Turn the engine upside down.
 Remove the lower crankcase bolts.

NOTE

Remove the bolts in two or more steps and in a crisscross pattern to prevent warpage.

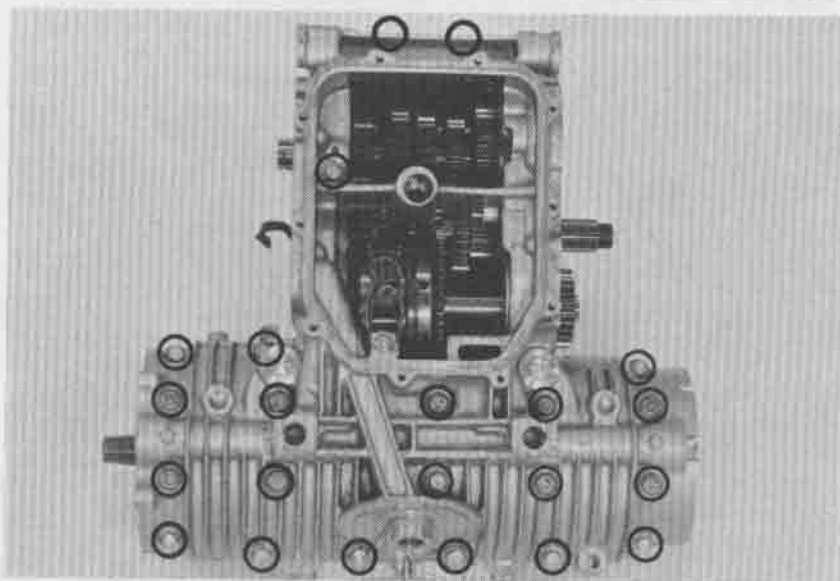
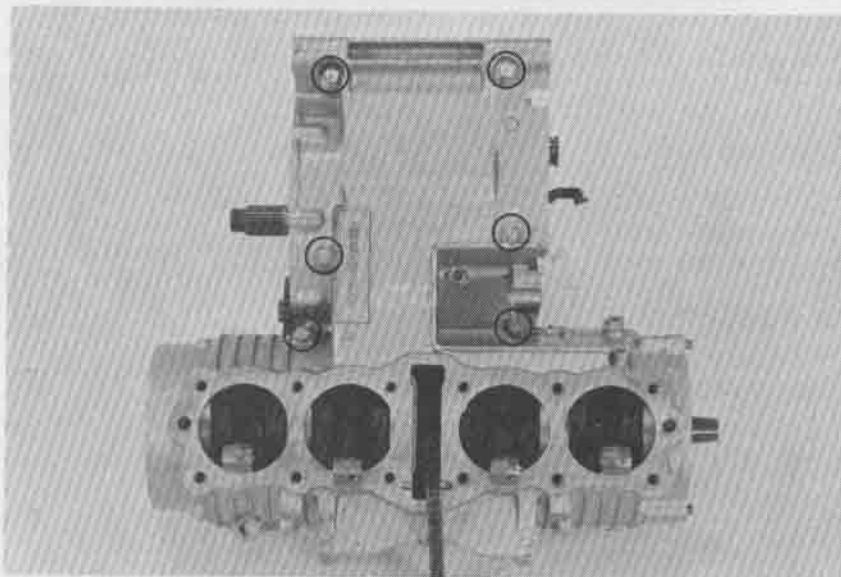
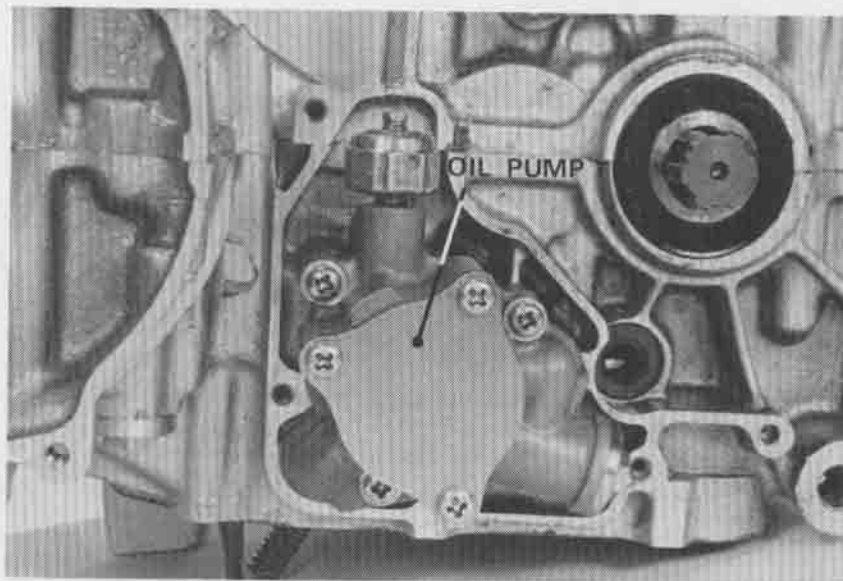



PRIMARY SHAFT REMOVAL

Remove the circlip.
Remove the primary drive gear with a gear puller.
Remove the bearing stopper plate.

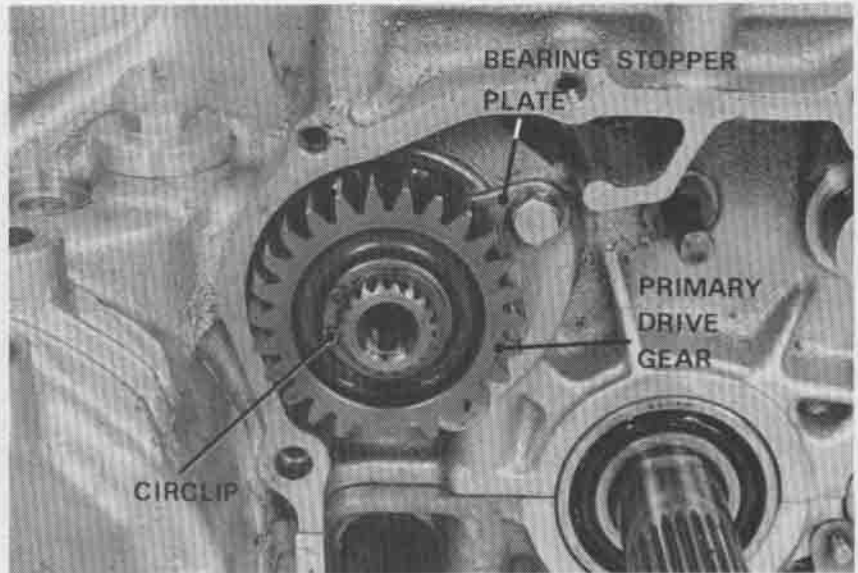

Disconnect the primary chain tensioner spring.

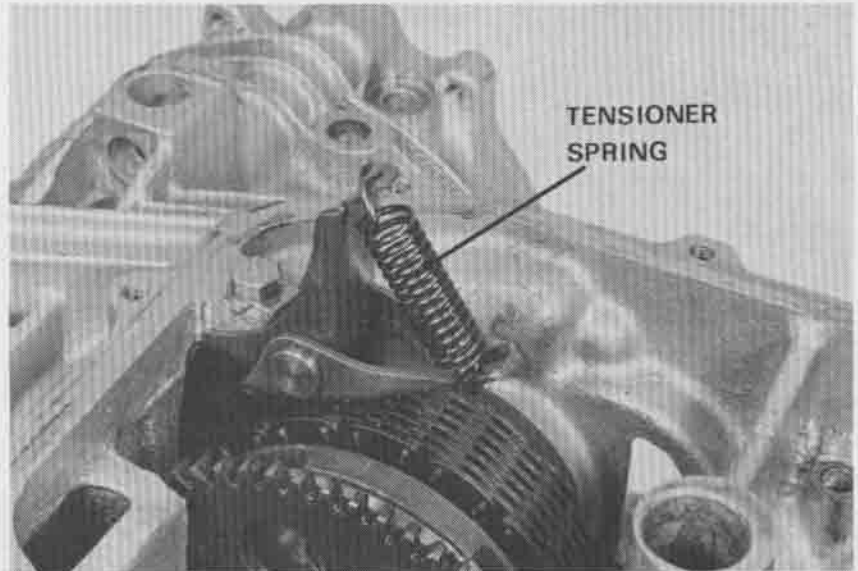

Remove the primary shaft with special tools.

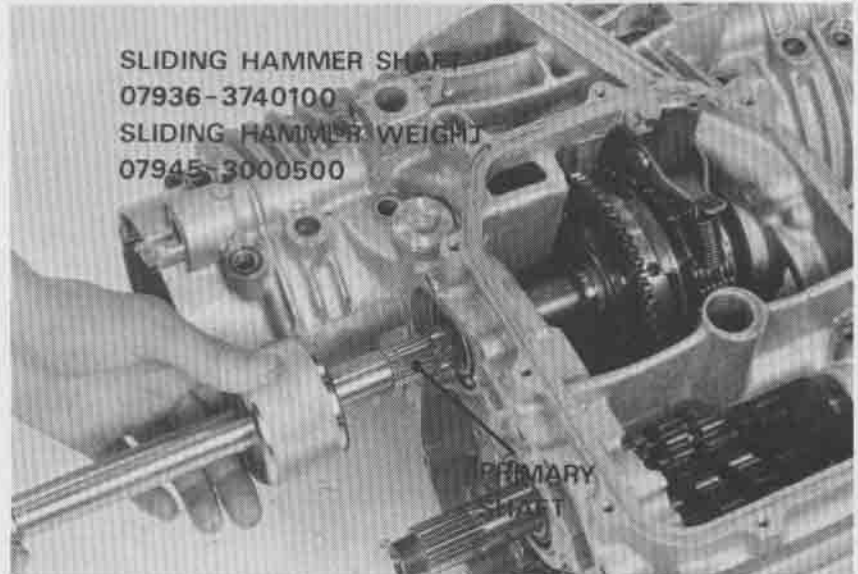

**CRANKCASE DISASSEMBLY**

Separate the crankcase.

CAUTION

Do not pry between the upper and lower cases.

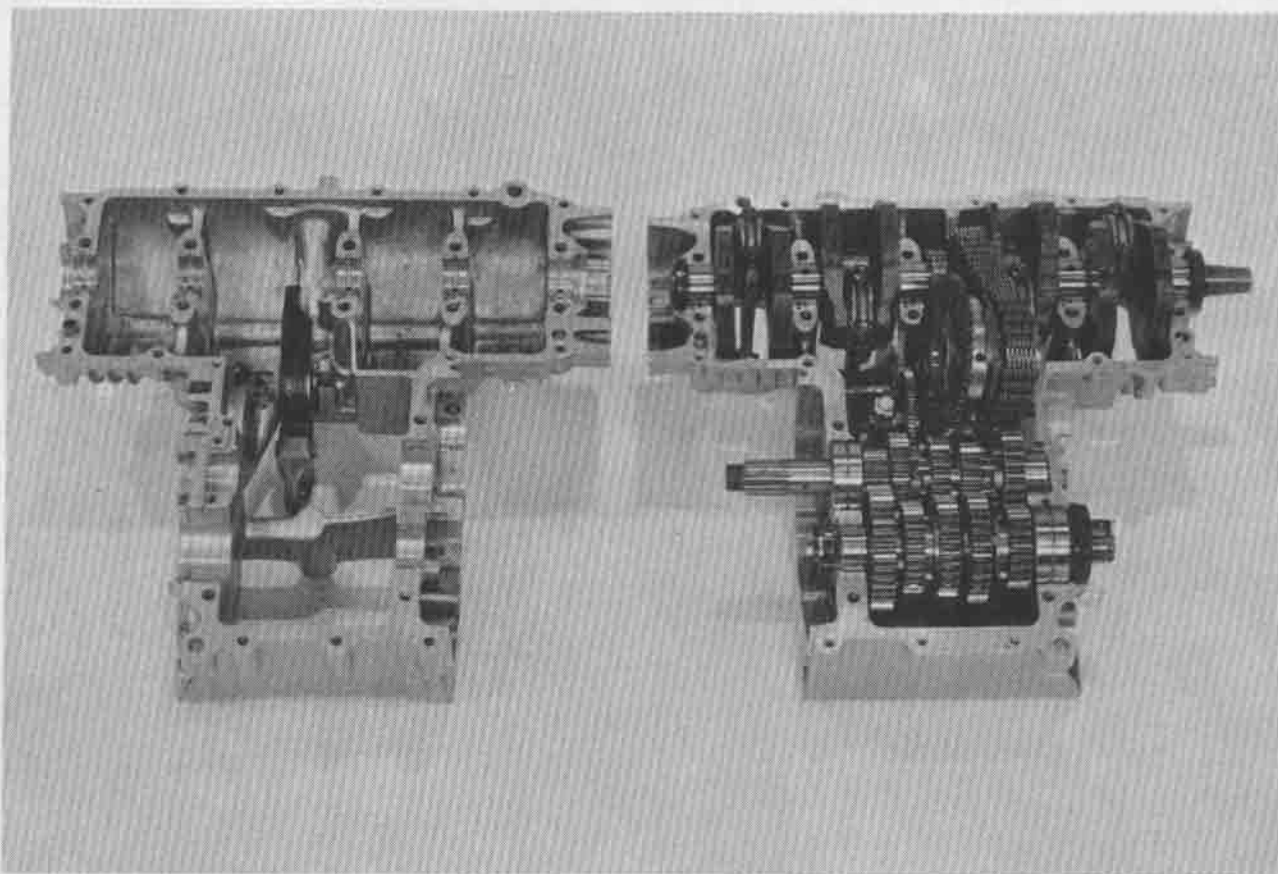
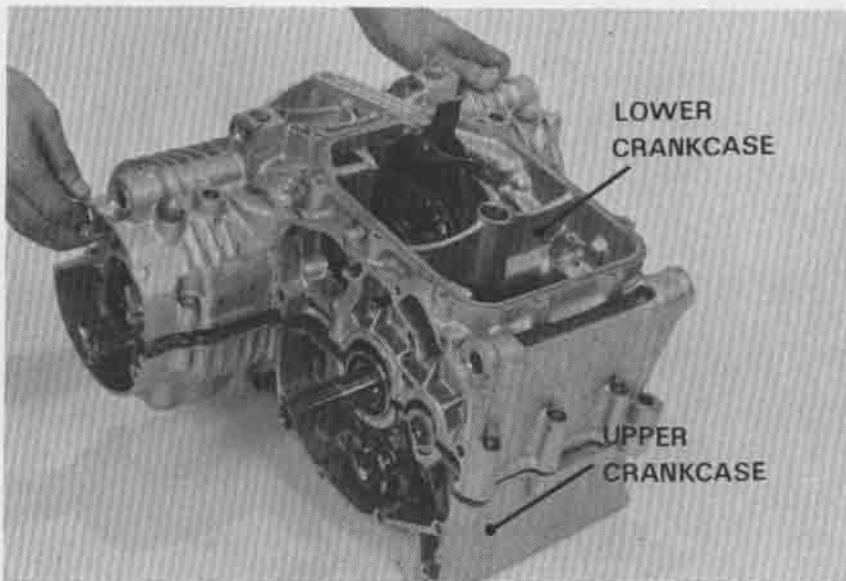



CRANKCASE ASSEMBLY

Clean the crankcase mating surfaces.
Apply liquid sealant to the mating surface of the lower crankcase.

NOTE

Do not apply sealant to the area near the main bearings and oil passages.

Apply molybdenum disulfide grease to the crankshaft main bearings.

Make sure the transmission bearings and oil seal are properly seated in the upper crankcase.

Position the primary chain and damper assembly in the crankcase.

Assemble the crankcase halves.

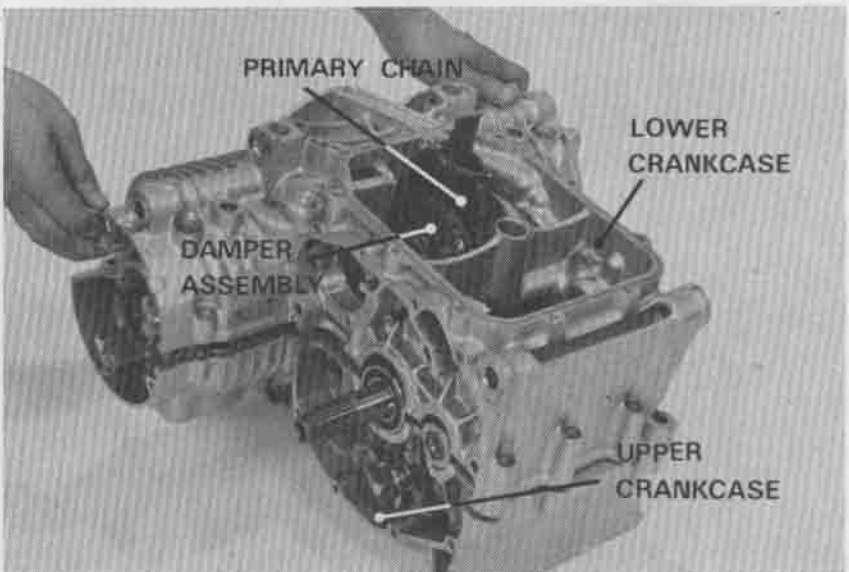
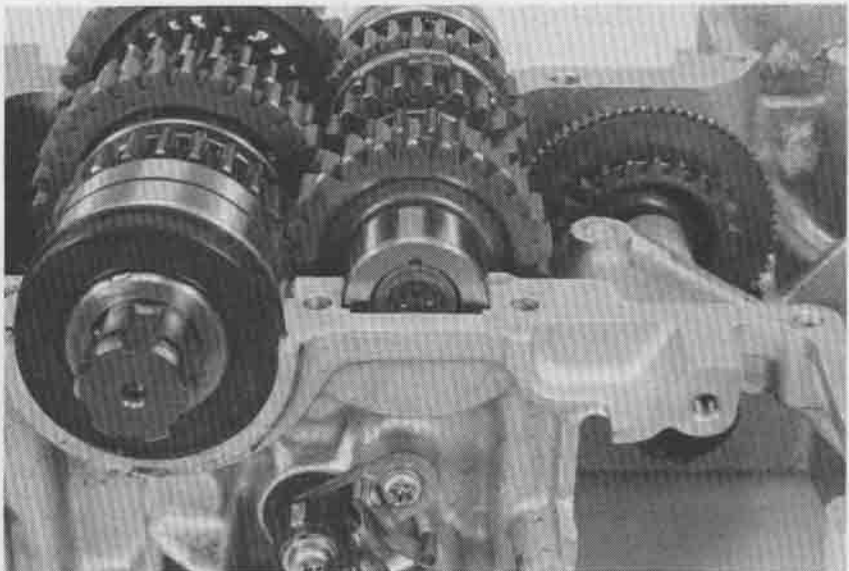
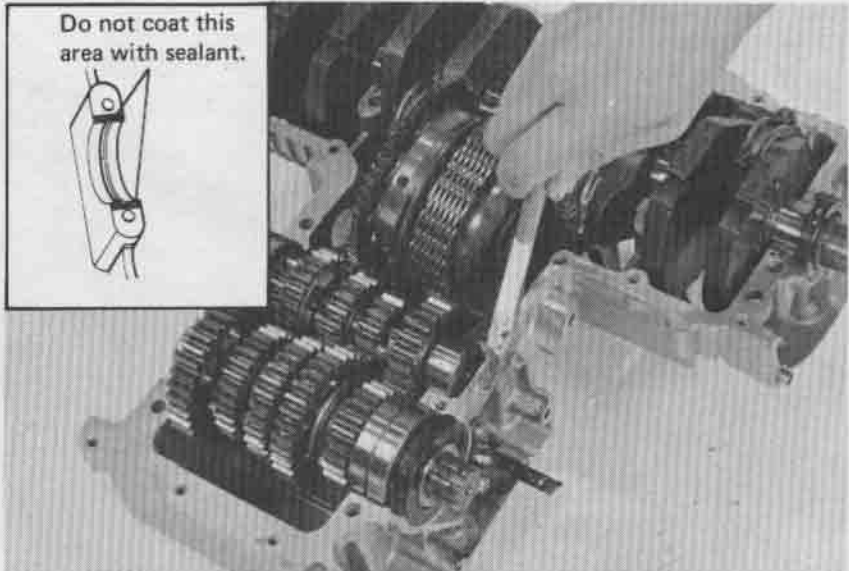



Insert the primary shaft and carefully drive it in with a plastic hammer.

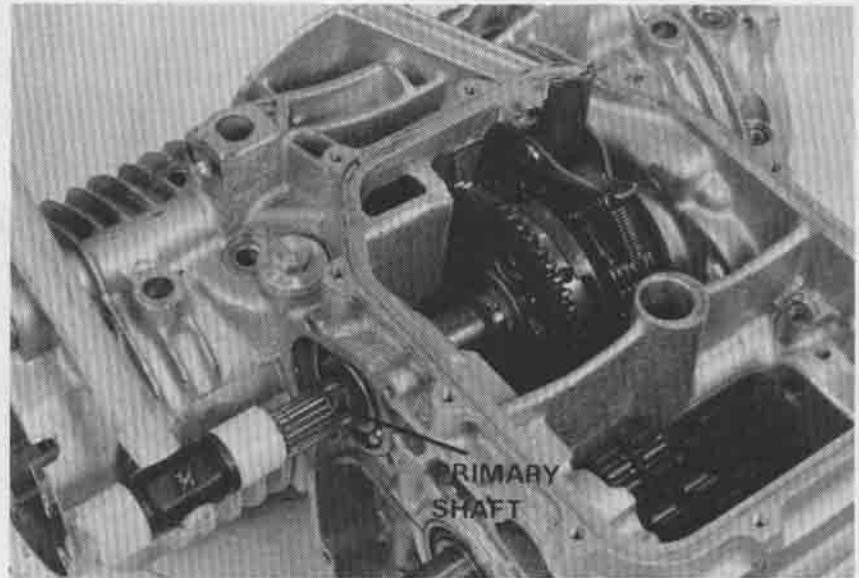

Install the bearing stopper plate.
Install the primary drive gear and circlip.

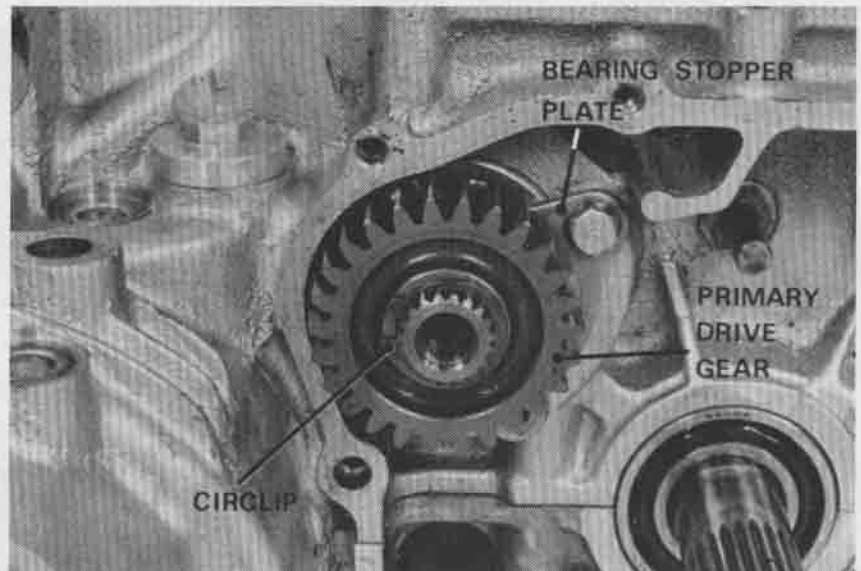

Connect the tensioner spring.





Tighten the bolts to the specified torque values in the sequence shown.

TORQUES:

8 mm bolt: 2.2–2.6 kg-m, (16–19 ft-lb)

6 mm bolt: 1.0–1.4 kg-m, (7–10 ft-lb)

NOTE

- Apply molybdenum disulfide grease to the threads and heads of the 10 crankshaft bolts.
- If the oil gallery cap is removed, apply molybdenum disulfide grease to the threads when installing it.

