



SERVICE INFORMATION	8-1	CLUTCH INSTALLATION	8-5
TROUBLESHOOTING	8-1	CLUTCH COVER INSTALLATION	8-8
CLUTCH COVER REMOVAL	8-2	CLUTCH CABLE REPLACEMENT	8-9
CLUTCH REMOVAL	8-3		

## SERVICE INFORMATION

### GENERAL INSTRUCTIONS

This section covers removal and installation of the clutch.  
This operation can be accomplished with the engine in the frame.

### SPECIAL TOOLS

#### Common Tools

Universal Holder	07725-0010101
Extension Bar	07716-0020500
Lock Nut Wrench Socket (26 x 30 mm)	07716-0020202

### TORQUE VALUES

Clutch lock nut 4.7-5.3 kg-m (34-38 ft-lb)

### SPECIFICATIONS

ITEM		STANDARD		SERVICE LIMIT	
Clutch	Lever free play (at lever end)	10-20 mm	(3/8-3/4 in)	—	
	Spring free length	36.8 mm	(1.45 in)	35.4 mm (1.39 in)	
	Spring preload/length	27.08-29.93 kg/24.1 mm (59.70-65.98 lb/0.95 in)		—	
	Disc thickness	A	3.42-3.58 mm	(0.135-0.141 in)	3.2 mm (0.13 in)
		B	2.62-2.78 mm	(0.103-0.109 in)	2.4 mm (0.09 in)
	Plate warpage	—		0.3 mm (0.012 in)	
	Clutch outer I. D.	29.990-30.005 mm (1.1807-1.1813 in)		30.05 mm (1.183 in)	
Clutch outer guide O. D.	29.959-29.980 mm (1.1795-1.1803 in)		29.94 mm (1.179 in)		

## TROUBLESHOOTING

### Clutch

Faulty clutch operation can usually be corrected by adjusting the free play.

#### Clutch slips

1. No free play
2. Discs worn
3. Springs weak

#### Motorcycle creeps with clutch disengaged

1. Too much free play
2. Plates warped

#### Excessive lever pressure

1. Clutch cable kinked, damaged or dirty
2. Lifter mechanism damaged

#### Clutch will not disengage

1. Too much free play
2. Plates warped

#### Clutch operation feels rough

1. Outer drum slots rough



## CLUTCH COVER REMOVAL

Drain the engine oil. (Page 2-2)  
 Remove the right foot peg.  
 Disconnect the clutch cable at the clutch arm.  
 Remove the clutch cover.

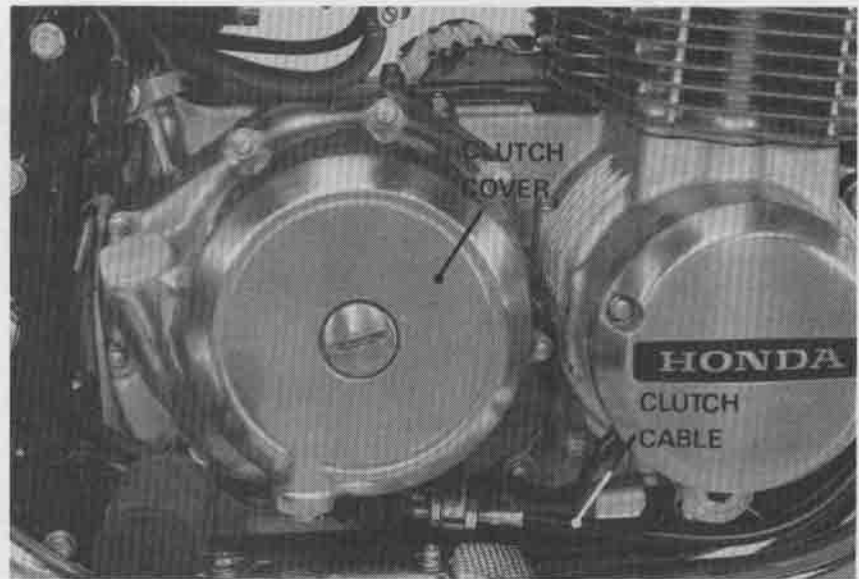

## CLUTCH LIFTER REMOVAL

Remove the adjusting screw, adjusting arm and lifter shaft.

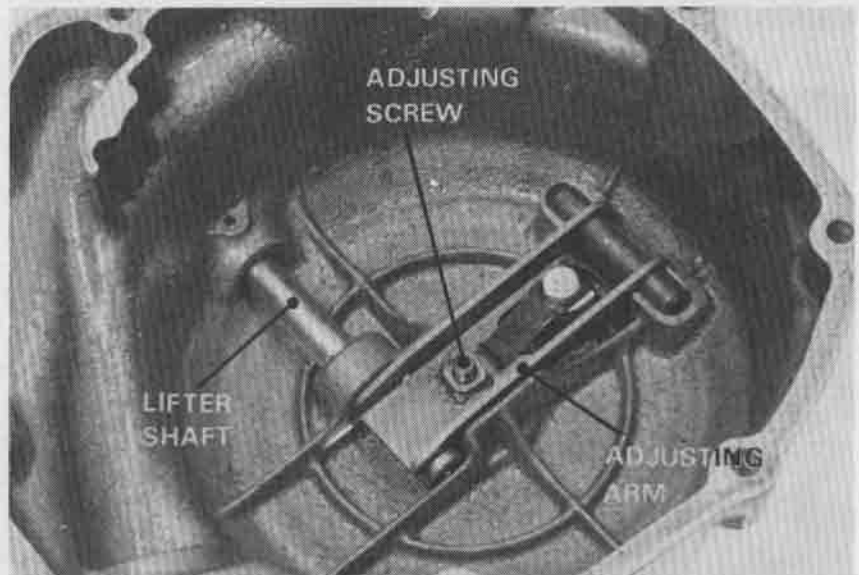

Remove the clutch lifter guide, bearing and bearing retainer.

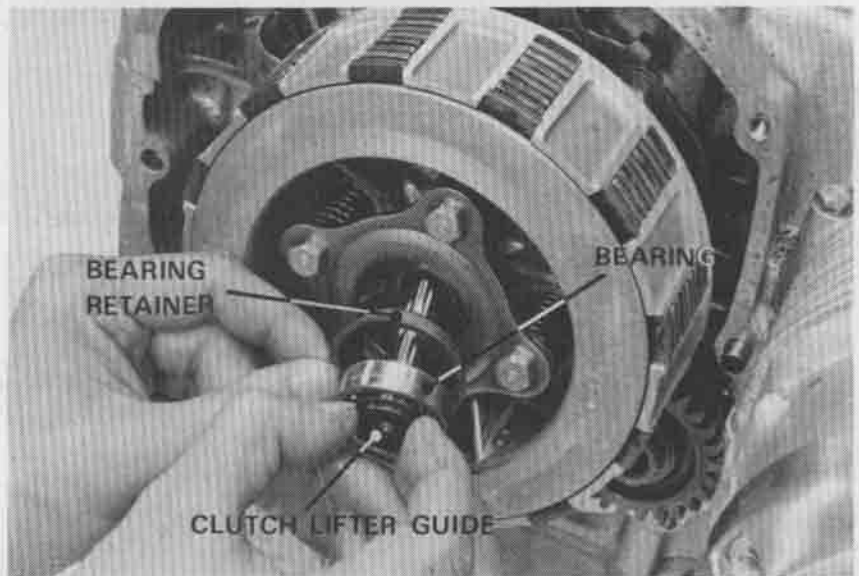



### CLUTCH REMOVAL

Use the universal holder if the drive chain is removed.

Shift the transmission into gear to lock the countershaft and mainshaft.

Block the drive sprocket to prevent it from turning.

When servicing the clutch in the frame, shift the transmission into gear, and press the brake pedal to lock the transmission gear shafts.

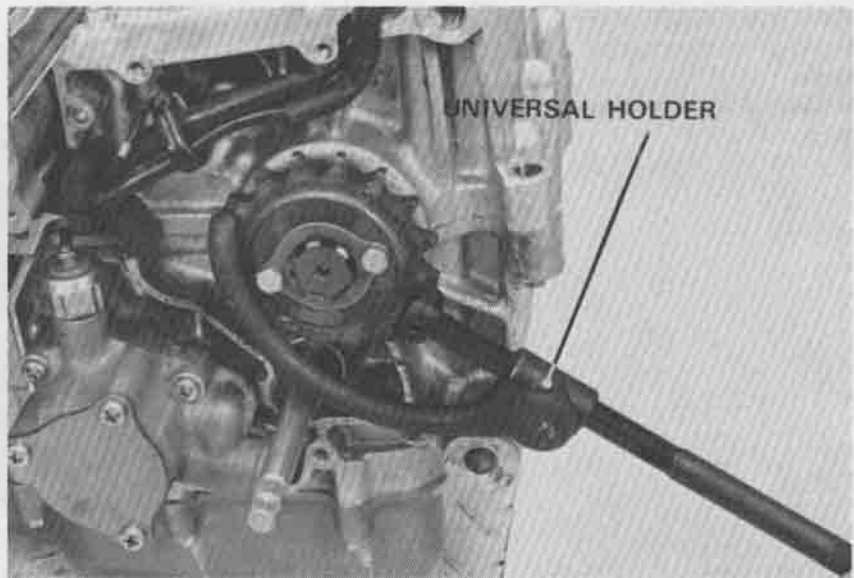

### CLUTCH LIFTER PLATE REMOVAL

Remove the bolts, lifter plate and springs.

#### NOTE

Loosen the bolts in a crisscross pattern in 2-3 steps.

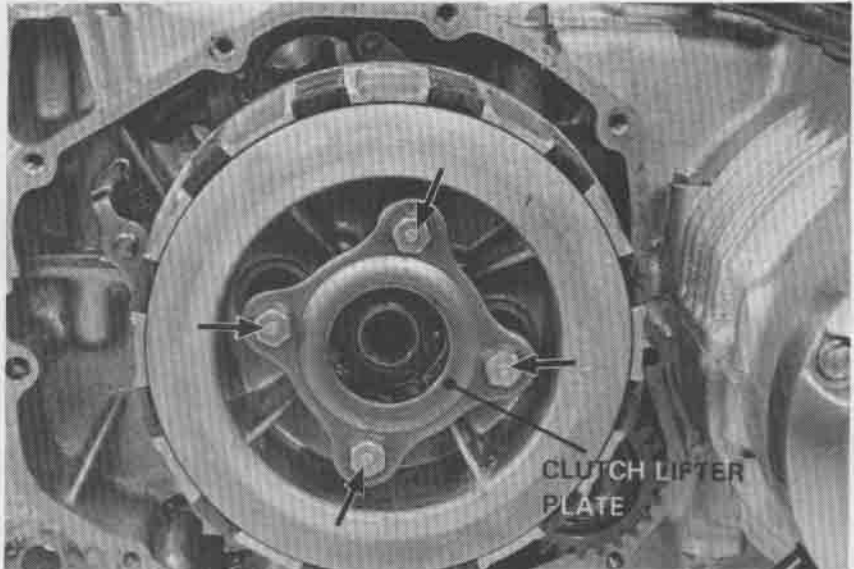

### CLUTCH CENTER, PLATES AND DISCS REMOVAL

Attach the lock nut wrench.

Remove the lock nut and lock washer.

Remove the clutch as a unit.

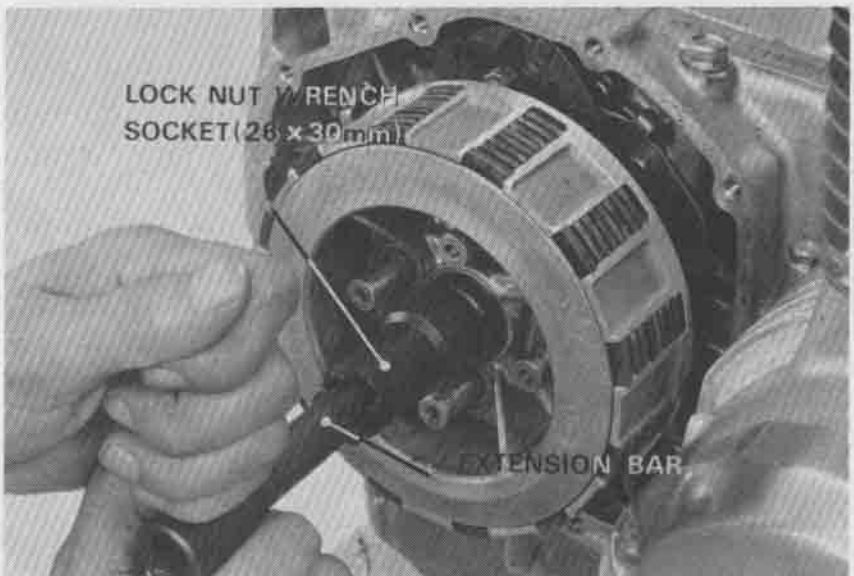



Remove the clutch center.  
 Remove the disc spring, discs A and B, and plates.  
 Remove the pressure plate and clutch outer guide.

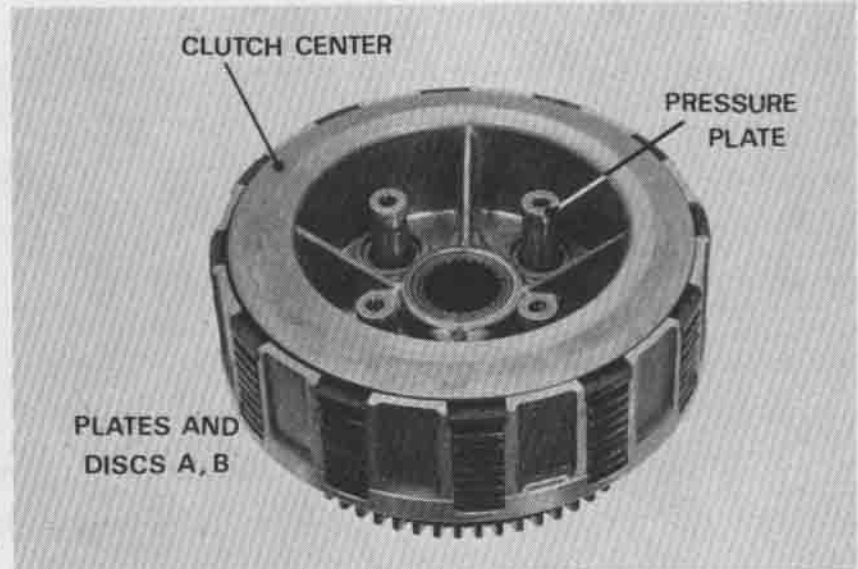

#### CLUTCH SPRING INSPECTION

Check spring free length.

**SERVICE LIMIT: 35.4 mm (1.39 in)**

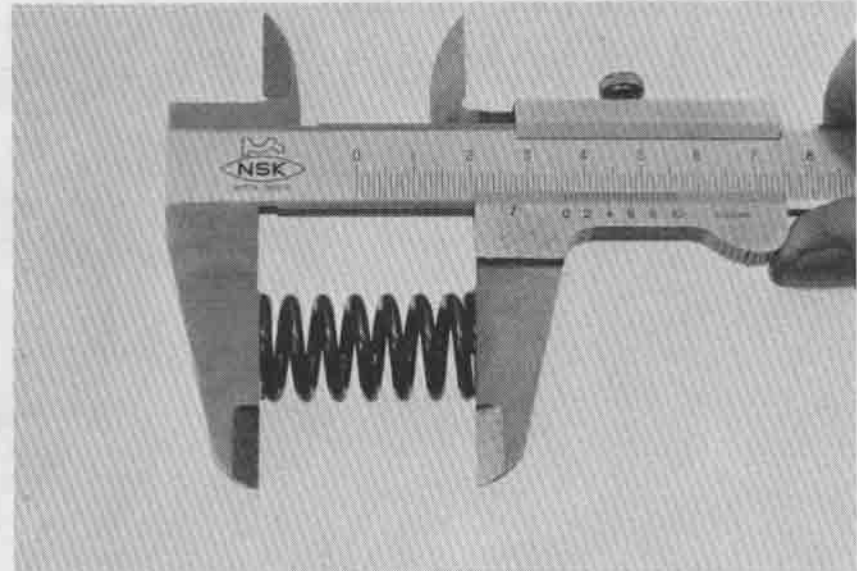

#### CLUTCH DISC INSPECTION

Replace the clutch discs if they show signs of scoring or discoloration.  
 Measure disc thickness.

**SERVICE LIMITS:**

**DISC A: 3.2 mm (0.13 in)**

**DISC B: 2.4 mm (0.09 in)**



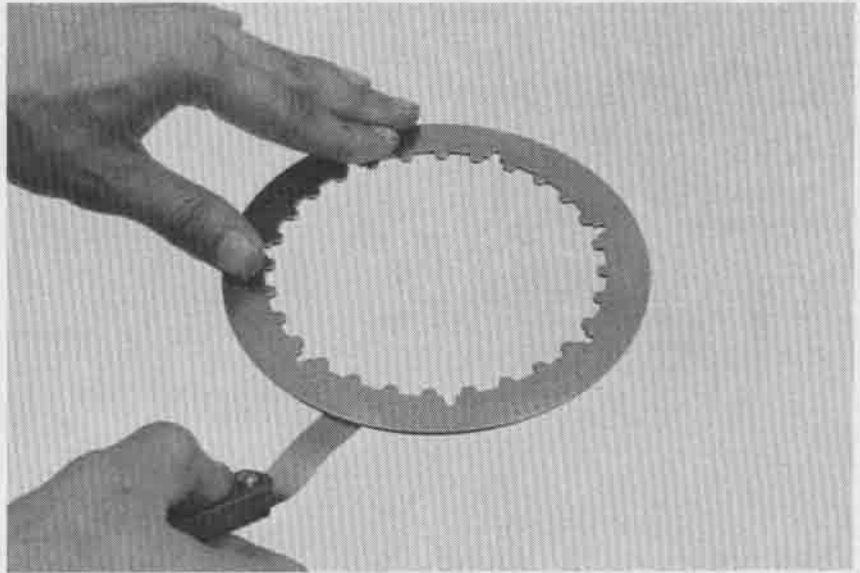



**PLATE INSPECTION**

Check plate for warpage on a surface plate, with a feeler gauge.

**SERVICE LIMIT:** 0.3 mm (0.012 in)



**CLUTCH OUTER AND OUTER GUIDE INSPECTION**

Check the slots in the outer drum for nicks, cuts or indentations made by the friction discs.

Measure the clutch outer I. D. and outer guide O. D.

**SERVICE LIMITS:**

**I.D.:** 30.05 mm (1.183 in)

**O.D.:** 29.94 mm (1.179 in)

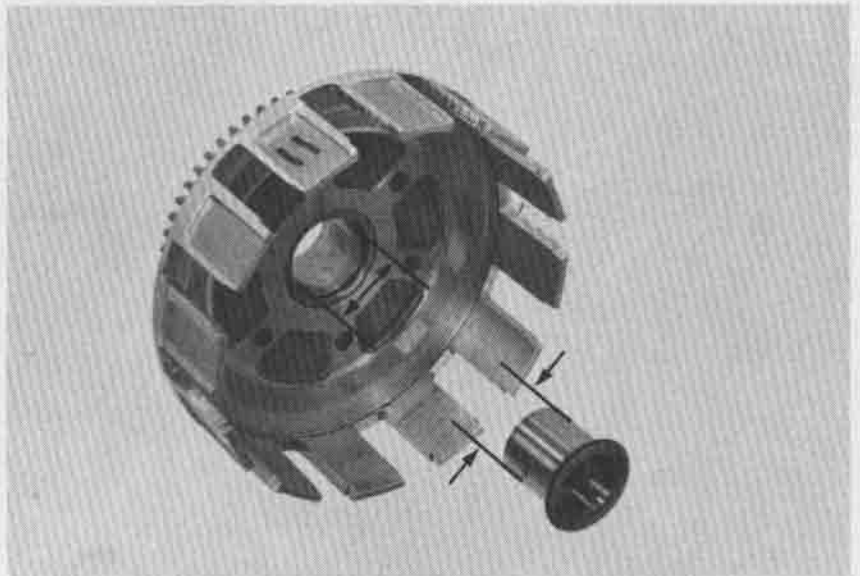

**CLUTCH INSTALLATION**

Install the thrust washer.

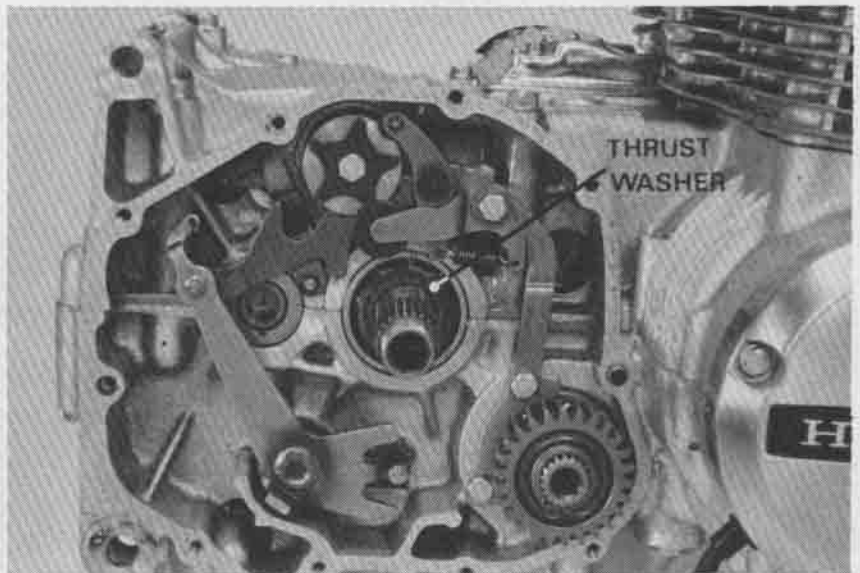



Assemble the clutch outer in the order listed below.

- Clutch outer guide
- Pressure plate
- Discs A (7) and plates (7) alternately
- Disc B
- Disc pressure spring
- Clutch center

**NOTE**

Before installing the clutch, coat the discs and plates with engine oil.

Install the disc pressure spring with the cupped side facing inside.

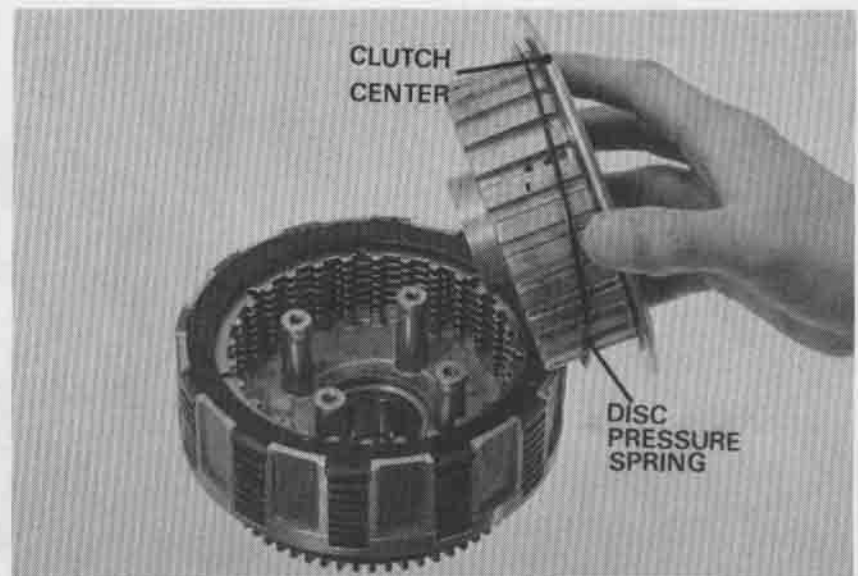
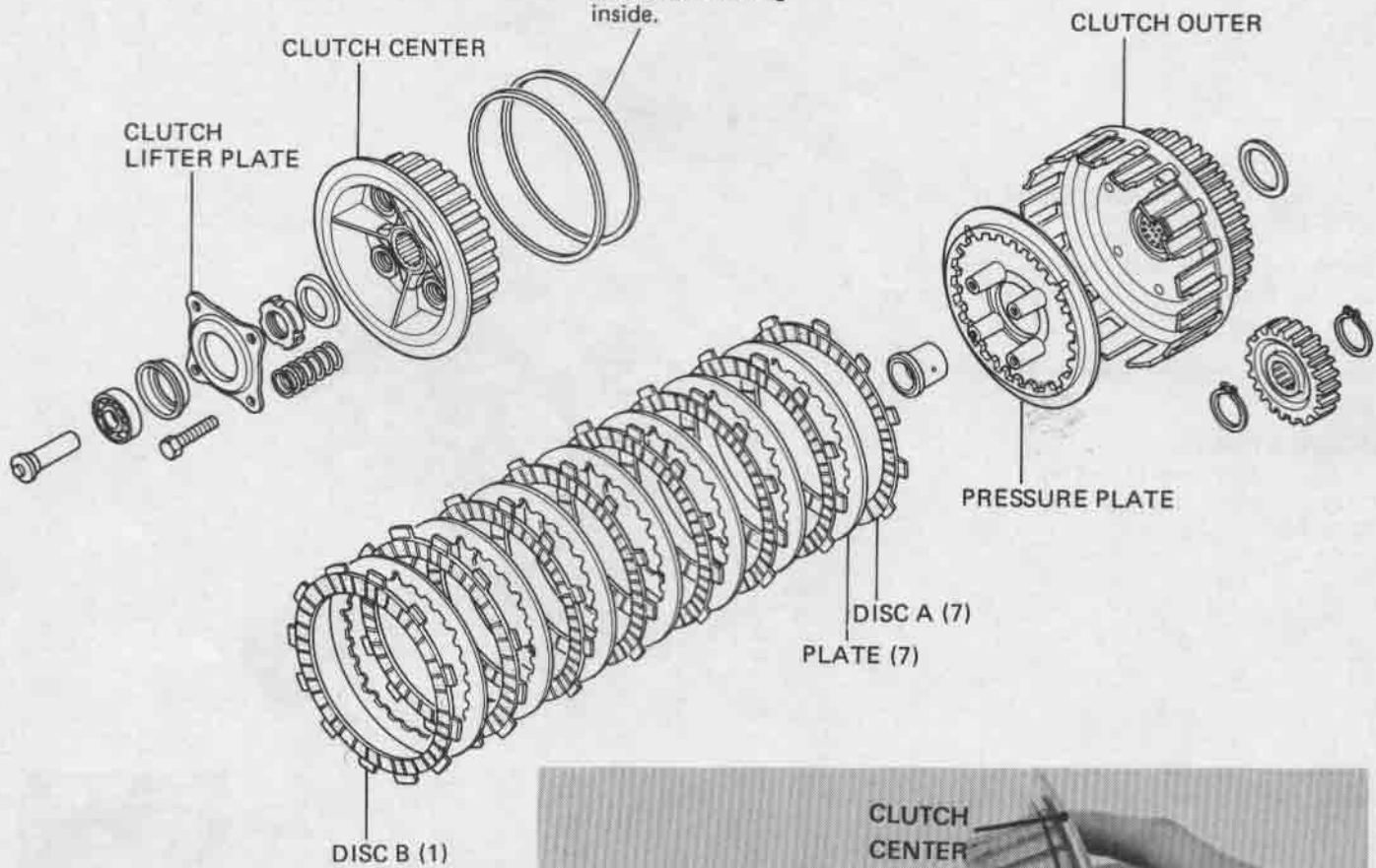



Align the splines by rotating the clutch center.

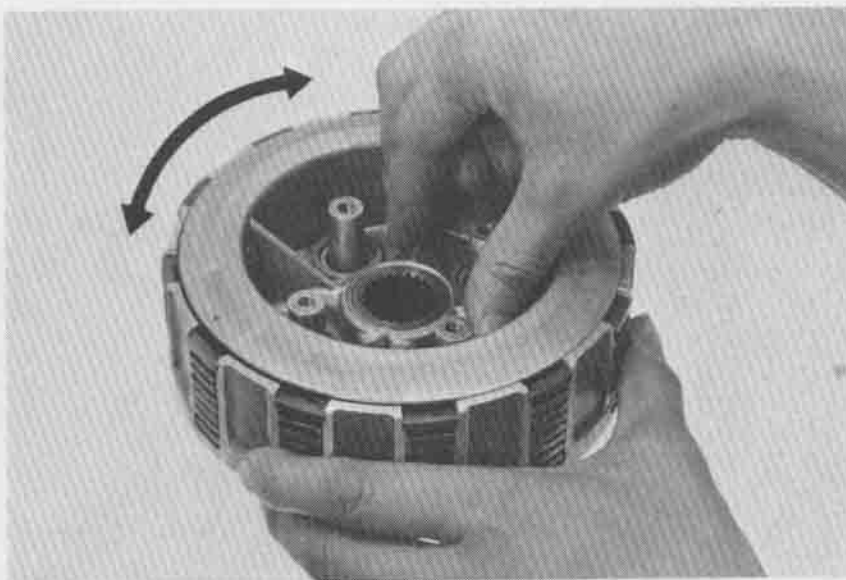

Install the clutch assembly.  
Install the lock washer and lock nut.

**NOTE**

Position the mark "OUTSIDE" on the lock washer facing out.

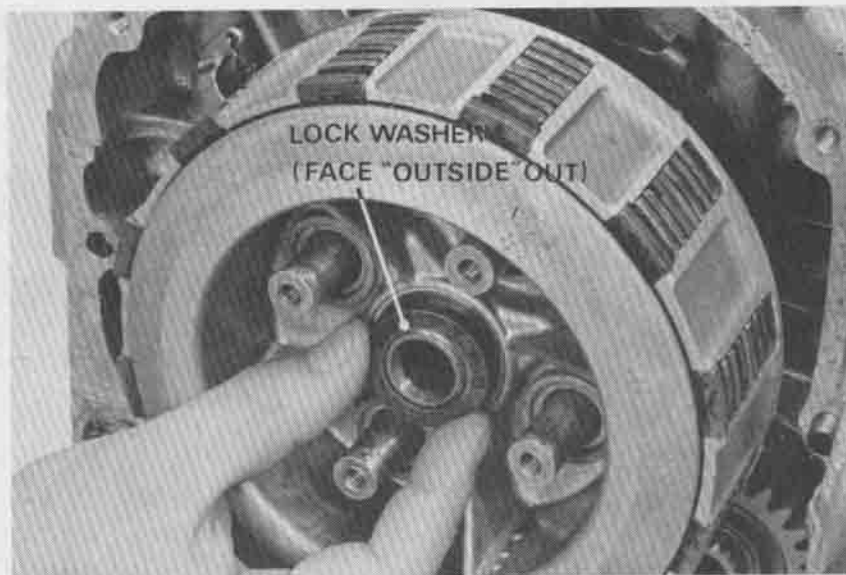

Tighten the lock nut.

**TORQUE: 4.7–5.3 kg-m (34–38 ft-lb)**

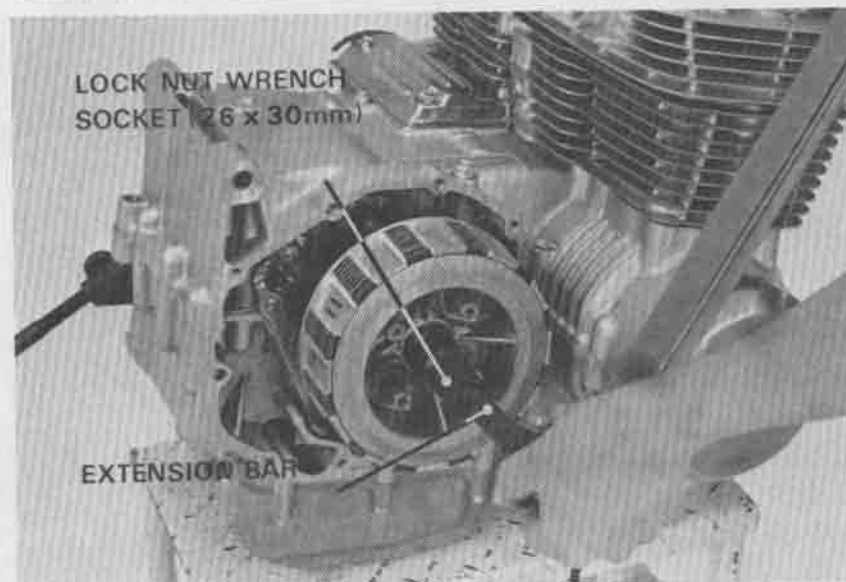





Install the clutch springs and lifter plate.  
Tighten the bolts.

**NOTE**

Install the lifter plate with the cupped side facing inside.

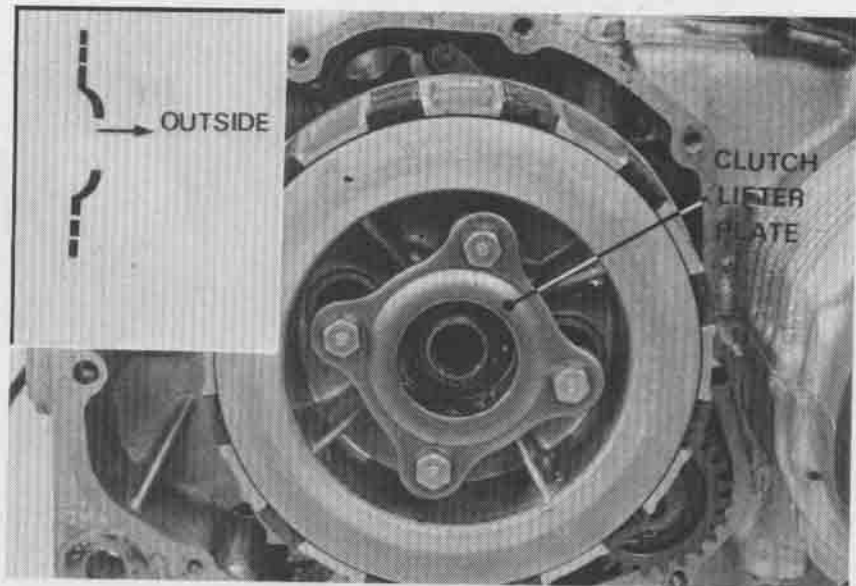

Install the bearing retainer, lifter guide and bearing.

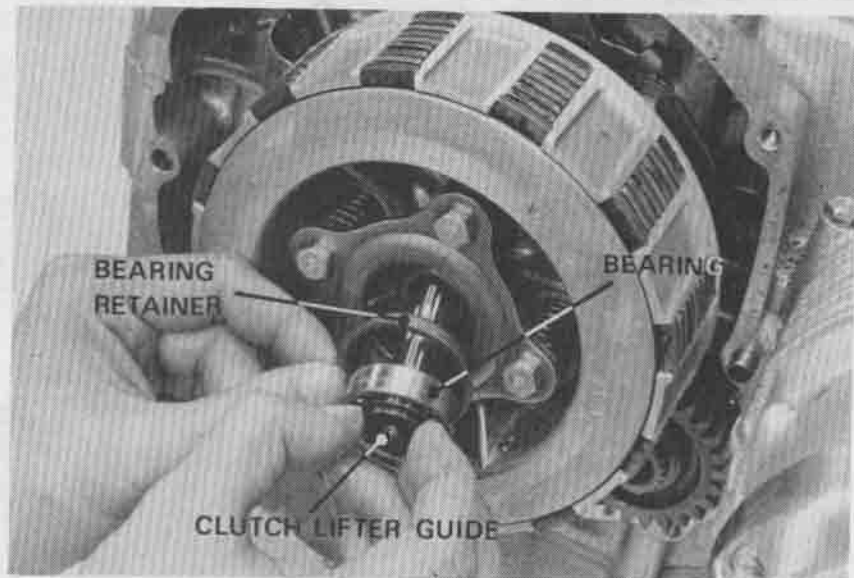

**CLUTCH COVER INSTALLATION**

Install the lifter shaft, adjusting screw, adjusting arm and spring.

Install the dowel pins and gasket, and then install the clutch cover.  
Connect the clutch cable.

Install the right foot page.

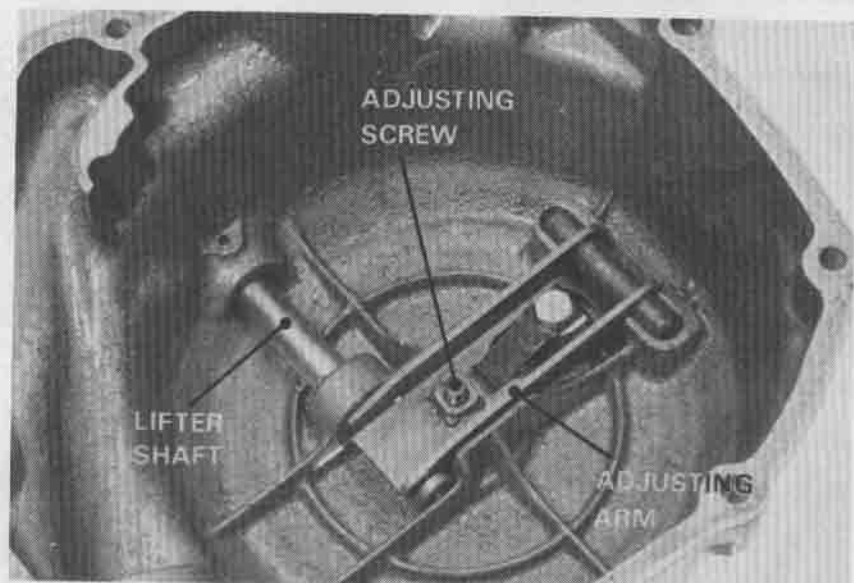
**TORQUE: 8.0–10.0 kg-m (58–72 ft-lb).**  
Adjust clutch free play (Page 3–16).





## CLUTCH CABLE REPLACEMENT

Remove the fuel tank.  
Remove the clutch cable from the lever.

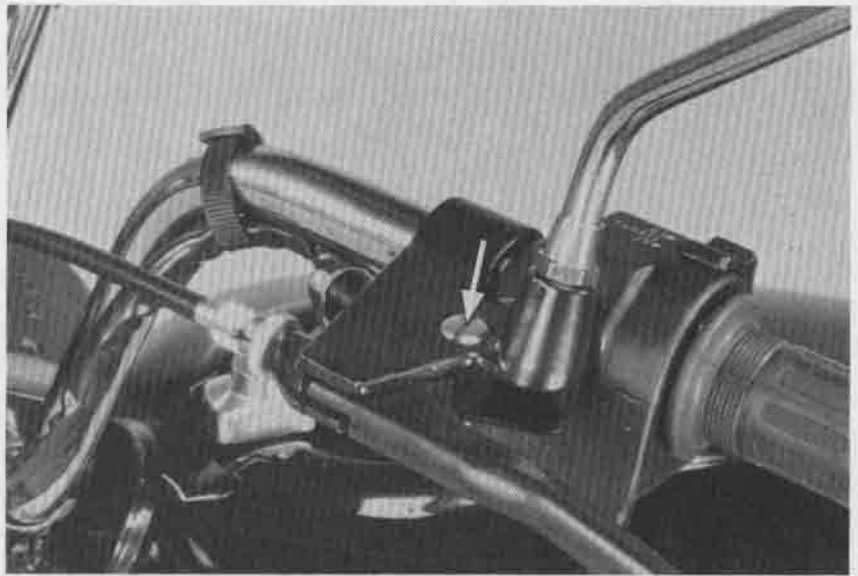

Loosen the clutch adjuster lock nuts and remove the clutch cable from the clutch lever.

### NOTE

Before removing the clutch cable, connect a string to the end of the cable so that a new cable can be installed easily by using this string as a draw cord.

Install a new clutch cable.  
Lubricate the clutch cable.  
After installation, adjust the clutch cable.  
(Page 3-16).

